

# Specifications

Hydraulic Rough Terrain Crane

## HSP-8040

40 Ton (36.29 metric ton)

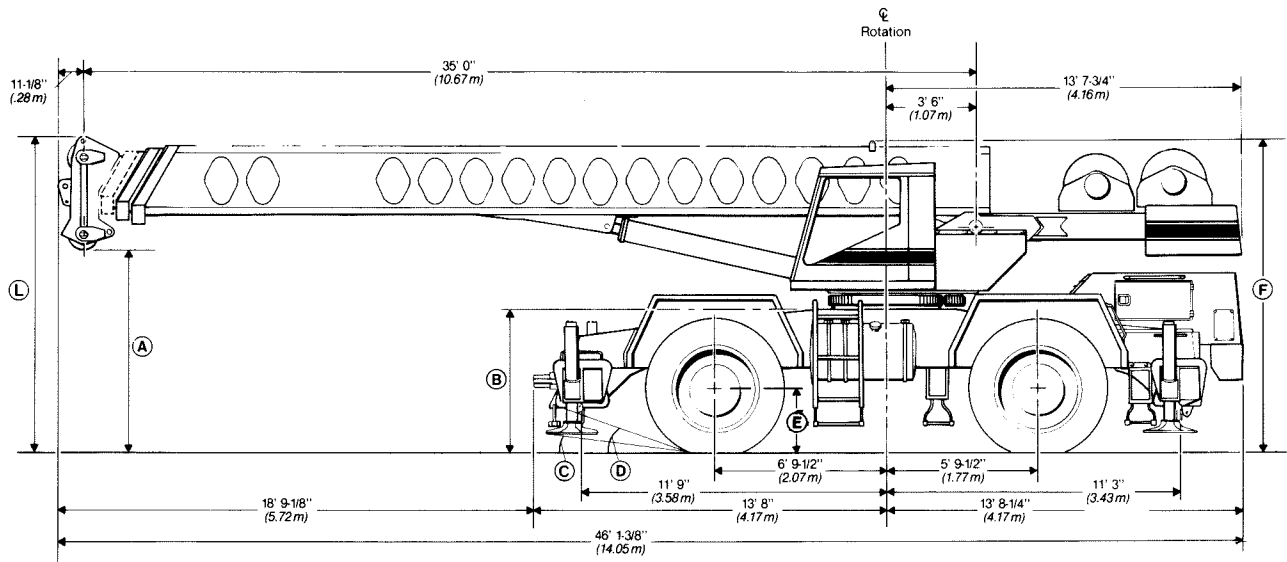

Not to Scale

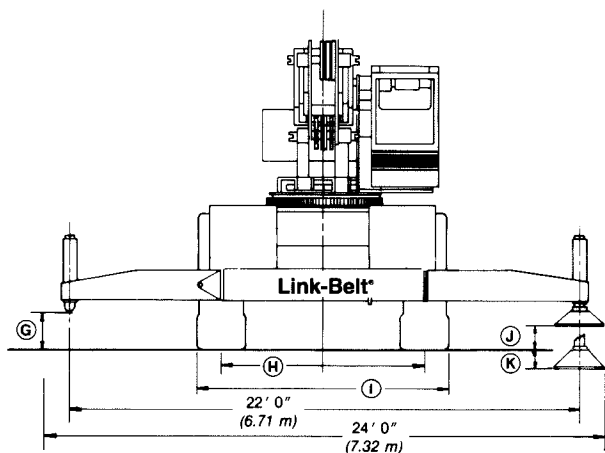

Not to Scale

General dimensions	feet	meters
Turning radius (4-wheel steer)	25'	7.62
Tailswing of counterweight:	13'8-5/8"	4.18

### Dimensions affected by tires

Tires	21.0 x 25 (24-PR)		26.5 x 25 (24-PR)		29.5 x 25 (22-PR)	
	feet	meters	feet	meters	feet	meters
A	7'10-1/4"	2.39	7'9-1/4"	2.37	7'10-3/4"	2.41
B	5'10-1/2"	1.79	5'9-1/2"	1.77	5'11"	1.80
C	10"	—	9"	—	10.97°	—
D	23°	—	22°	—	24.5°	—
E	2'7-1/2"	.80	2'6-3/8"	.77	2'8"	.81
F	12'3-1/2"	3.75	12'2-1/2"	3.72	12'4"	3.76
G	1'8-7/8"	.53	1'7-3/4"	.50	1'9-5/16"	0.54
H	7'9"	2.36	8'6-1/2"	2.60	8'2-1/2"	2.50
I	9'8"	2.95	10'10"	3.30	10'9-1/2"	3.28
J	10-7/8"	.28	9-3/4"	.25	11-5/16"	.29
K	9-1/4"	.23	10"	.25	7-9/32"	.18
L	12'7-3/4"	3.85	12'6-3/4"	3.83	12'8-1/4"	3.86

# Upperstructure

## ■ Boom

**Patented design.** Boom side plates have diamond shaped impressions for superior strength to weight ratio and 100,000 psi (689.5 MPa) steel angle chord for lateral stiffness. Boom sections are supported by wear shoes both vertically and horizontally.

**Load Moment Indicator** — Audio-visual warning system with anti-two block and function kickouts. Constant display of boom length and angle, tip height, radius of load, machine configuration, allowed load, actual load and % of allowed load. Presettable alarms for maximum and minimum boom angles, maximum tip height and maximum boom length.

**Standard boom** — 35' 0" - 85' 0" (10.67m - 25.91 m) 3-section full power boom.

**Optional boom** — 35' 0" - 110' 0" (10.67 m - 33.53 m) 4-section boom includes base section, two power sections, and manual fourth section. Fourth section is power pinned by manually activating a cylinder locking system.

**Boom head** — **Standard;** Four 16-3/8" (0.42 m) root diameter head sheaves with five 16-3/8" (0.42m) available to handle up to 10 parts of wire rope. Two easily removable wire rope guards; rope dead end lugs provided on each side of boom head.

**Auxiliary lifting sheave** — *Optional;* Single 16-3/8" (0.42 m) root diameter head sheave with removable wire rope guard, mounted to boom, for use with one or two parts of line off the optional auxiliary winch. Does not affect erection of fly or jib, or use of main head sheave for multiple reeving.

**Boom elevation** — Two hydraulic cylinders with holding valves. Self aligning steel bushings. Hand and optional foot controls for controlling the boom elevation from -3° to 78°.

## ■ Fly

*Optional* — 33' 0" (10.06 m) stowable one-piece lattice type.

## ■ Jib

*Optional* — 25' 0" (7.62 m) stowable A-frame which can be offset 5°, 17.5°, and 30° Attaches to fly only.

## ■ Cab and Controls

Environmental cab; isolated from sound and vibration by a neoprene seal. All windows are tinted and tempered safety glass. Sliding rear and right side windows and swing up roof window for maximum visibility and ventilation. Slide-by-door opens to 3'0" (0.91 m) width. 6-way adjustable operator's seat 4-way adjustable tilt/telescoping steering wheel. Control levers for swing, boom telescope, winch and boom hoist with foot control swing brake. Outrigger controls, sight level bubble. Optional foot control for boom hoist.

### Cab instrumentation

Dash mounted gauges for hydraulic oil temperature, converter temperature, oil pressure, water temperature, fuel and volt-meter.

## ■ Swing

Bi-directional hydraulic swing motor mounted to a planetary reducer for 360° continuous smooth swing at 2.45 r.p.m.

**Swing brake** — **Standard;** foot operated, spring released disc brake mounted on the speed reducer.

**Swing lock** — **Standard;** 360° position pin type and a two position travel lock operated from the operator's cab.

### Counterweight

Pinned to upperstructure frame.

## ■ Hydraulic System

**Main pump** — Triple gear-type pump. Combined pump capacity 161 gpm (609.4 lpm). Powered by torque converter through a pump disconnect. Pump disconnect is a jaw-type clutch engaged/disengaged from carrier. Maximum system pressure at 2900 p.s.i. (199.94 Bars).

**Steering/outrigger pump** — Single gear-type pump, 28 gpm (106 lpm) maximum. Powered by torque converter through a straight mechanical drive. Pump operates at 2,700 p.s.i. (186.25 bars).

### Reservoir

140 gallon (530.0 L) capacity. Diffusers for deaeration.

**Filtration** — One six-micron filter located inside of the hydraulic reservoir. Accessible for easy replacement.

**Control valves** — Six separate control valves allow simultaneous operation of all crane functions.

## ■ Load Hoist System

**Standard** — Model 2M main winch with two-speed motor and automatic brake; power up/power down mode of operation. Bi-directional gear type hydraulic motor.

*Optional* — Model 2M auxiliary winch with two-speed motor and automatic brake, power up/power down mode of operation. Bi-directional, gear-type hydraulic motor.

*Optional* — Model 3M winch with power up/power down, two-speed motor and exclusive controlled true gravity free fall. Available on main winch only.

**Line pulls and speeds** — Maximum line pull 15,870 lbs. (7 199 kg) and maximum line speed 548 f.p.m. (167.03 m/min.) on 17" (0.43 m) root diameter standard smooth drum.

## ■ Additional Equipment - Standard

Rear view mirrors, seat belt, fire extinguisher, backup alarm, travel lights and sound suppressed cab.

## ■ Additional Upperstructure Equipment - Optional

Propane heater, diesel heater, air conditioning, drum rotation indicators, 40-ton (36.29 metric ton) hook block, 8-1/2 ton (7.71 metric ton) hook ball and swivel, rear steer indicator, boom mounted working light, engine monitoring system, top hatch wiper, windshield washer, hand throttle, lifting lugs, tachometer, amber rotating beacon, cab spotlight and boom hoist foot control.

# Carrier

## ■ Type

9' 9" (2.97 m) wide, 151" (3.84 m) wheelbase.

4 × 4 × 4 — (4-wheel steer, 4-wheel drive)

**Standard;** for rough terrain with limited turning area.

4 × 4 × 4 — (4-wheel steer, 4-wheel drive)

*Optional;* no spin differential on front axle; for rough terrain with limited turning area.

**Frame** - 100,000 p.s.i. (689.5 MPa) steel, double walled construction with integral 100,000 p.s.i. (689.5 MPa) steel outrigger boxes.

## ■ Axles

**Front, Standard** — heavy duty planetary drive/steer type.

**Rear, Standard** — heavy duty planetary drive/steer type.

**Front, Optional** — heavy duty no spin high traction differential, planetary drive/steer type.

## ■ Suspension

**Front axle** - Rigid mounted to frame.

**Rear axle** — Pin mounted on bronze bushings. automatic hydraulic rear axle oscillation lockout cylinders engage when upperstructure rotates past 2-1/2° of centerline.

## ■ Tires

**Front and rear**

**Standard** — 21.0 × 25 (24-PR)  
Earth mover type

*Optional* — 26.5 × 25 (24-PR)  
or 29.5 × 25 (22-PR)  
Earth mover type

## ■ Brakes

**Service** — Air over hydraulic, drum type brakes at each wheel end. Drum diameter 20-1/4" (0.51 m). Shoe width 4" (101.6 mm).

**Parking/emergency** — Disc caliper type spring applied, air released, fade resistant; cab controlled, mounted on front axle.

## ■ Steering

Hydraulic two wheel, four wheel and "crab" steering.

## ■ Transmission

3-speed, 2-range power shift transmission. Six speeds available forward and 2 reverse. Front axle disconnect for two or four-wheel drive.

## ■ Outriggers

Four hydraulic, beam and jack outriggers. Vertical jack cylinders equipped with integral holding valve. Beams extend to 22' 0" (6.71 m) centerline-to-centerline and retract to within 9'9" (2.97 m) overall width with floats stored. Equipped with stowable, lightweight 24" (0.61 m) diameter floats. Controls and sight level bubble located in upperstructure cab.

## ■ Additional Equipment - Standard

Cab steps, 2 front carrier steps, skid resistant finish on carrier deck, storage compartment and fenders.

## ■ Additional Equipment - Optional

Towing shackles, ether injection, no spin differential on front axle, spare tires and rims, pintle hook, jack cylinder hose covers, propane fired engine block heater, air dryer and emergency steering system.

## Travel speeds and gradeability

Engine	Tires	Maximum Speed		Gradeability at stall	Maximum tractive effort at stall		Gradeability at 1.0 mph (1.61 km/h)	Maximum tractive effort at 1.0 mph (1.61 km/h)	
		mph	km/h		pounds	kgs.		pounds	kgs.
GM 6V-53N	21.0 × 25	21	33.79	175%	79,923	36 253	56%	45,947	20 841
	*26.5 × 25	21	33.79	168%	79,145	35 900	55%	45,499	20 638
	*29.5 × 25	21	33.79	147%	76,177	34 554	52%	43,793	19 865
Cummins 6CT 8.3 *	21.0 × 25	21	33.79	275%	86,393	39 188	63%	49,789	22 584
	*26.5 × 25	21	33.79	254%	85,551	38 806	62%	49,304	22 364
	*29.5 × 25	21	33.79	200%	82,343	37 351	59%	47,455	21 526

\* Optional Equipment

Engine	GM 6V-53N	Cummins 6CT 8.3 *
Cylinders - cycle	6 - 2	6 - 4
Bore	3-7/18" (98.43 mm)	4.49" (114.05 mm)
Stroke	4 - 1/2" (114.30 mm)	5.32" (135.13 mm)
Displacement	318 cu. in. (5 211 cm <sup>3</sup> )	504 cu. in. (8 259 cm <sup>3</sup> )
Compression ratio	21:1	17.3 : 1
Maximum brake h.p.	205 at 2700 r.p.m.	215 at 2700 rpm
Idle speed	500 r.p.m.	600 r.p.m.
Peak torque	445 lbs.	567 ft. lbs. at 1500 rpm
Electrical system	12 volt negative ground	12 volt negative ground
Fuel capacity	100 gallons (378.5 L)	100 gallons (378.5 L)
Alternator	80 amp Delco	80 amp Delco
Crankcase capacity	18.4 quarts (17.41 L)	18.9 quarts (17.89 L)
Air compressor	12 c.f.m. (0.34 m <sup>3</sup> /min)	13.2 c.f.m. (0.37 m <sup>3</sup> /min)

\* Optional Equipment

## Axle Loads

Base machine with standard 35'-85' (10.67 m-25.91 m) 3-section boom, main winch with 2-speed hoisting and power up/down, 600' (182.88 m) 3/4" (19 mm) wire rope, 4 x 4 x 4 carrier with GM 6V-53N engine, 21.0 x 25 tires, full fuel, rear counterweight, 4-sheave head machinery.	GVW <sup>Ⓞ</sup>		Upper facing front				Upper facing rear			
			Front axle		Rear axle		Front axle		Rear axle	
	lbs.	kgs.	lbs.	kgs.	lbs.	kgs.	lbs.	kgs.	lbs.	kgs.
	75,068	34 044	34,690	15 732	40,378	18 312	28,292	12 831	46,776	21 214
35'-110' (10.67 m-33.52 m) 4-section boom	1,952	885	1,808	820	144	65	-1,212	-550	3,164	1 435
33' (10.06 m) lattice fly stowed	1,040	472	1,660	753	-620	-281	-703	-319	1,743	790
25' (7.62 m) A-frame jib stowed	1,128	512	1,438	652	-310	-141	-402	-182	1,530	694
Hook block at bumper	750	340	1,212	550	-462	-210	1,212	550	-462	-210
Headache ball at bumper	325	147	525	238	-200	-91	—	—	—	—
Auxiliary lifting sheave	150	68	468	212	-318	-144	-330	-150	480	218
Fly and jib stowage brackets	230	104	343	156	-113	-51	-132	-60	362	164
26.5 x 25 tires	820	372	410	186	410	186	—	—	—	—
29.5 x 25 tires	980	444	490	222	490	222	—	—	—	—

<sup>Ⓞ</sup> Adjust gross vehicle weight and axle loading according to components weight.  
**Note:** All weights are  $\pm 3\%$ .

Tire	Max. Axle Load @ 20 mph (32.7 km/hr)
21.00 x 25 (24-PR)	44,000 lbs. (19 957 kgs.)
26.50 x 25 (24-PR)	44,200 lbs. (20 047 kgs.)
29.50 x 25 (22-PR)	49,500 lbs. (22 451 kgs.)

• Link-Belt is a registered trademark. Copyright 1991.

We are constantly improving our products and therefore reserve the right to change designs and specifications.

**Link-Belt Construction Equipment Company** Lexington, Kentucky

A unit of Sumitomo Construction Machinery Co., Ltd.

# Lifting Capacities

## Hydraulic Rough Terrain Crane

### HSP-8040 40-ton (36.29 metric ton)

#### 4-Section Boom

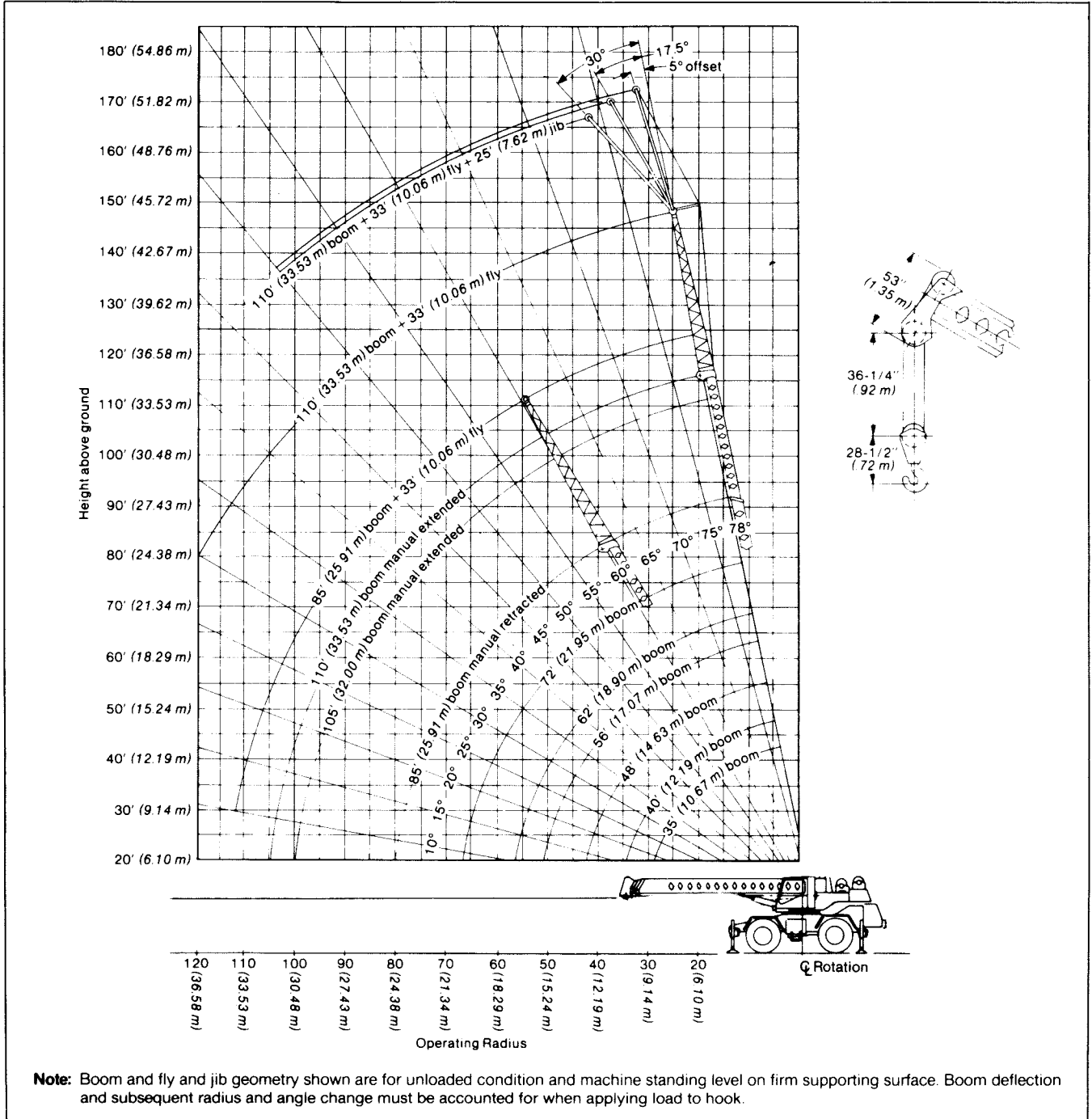

# HSP-8040 Lifting Capacities

Refer to Operating Instructions page 4

35'-110' (10.67-33.53 m) 4-section boom

Capacities On Outriggers <sup>①</sup> Manual Section Retracted														77' (23.47 m) boom plus 33' (10.06 m) fly			85' (25.91 m) boom plus 33' (10.06 m) fly					
Load radius	35' (10.67 m)		40' (12.19 m)		48' (14.63 m)		56' (17.07 m)		62' (18.90 m)		72' (21.95 m)		85' (25.91 m)		Boom angle	Front	360°	Boom angle	Front	360°		
	Front	360°	Front	360°	Front	360°	Front	360°	Front	360°	Front	360°	Front	360°								
10' 3.05 m	80,000 36,288	80,000 36,288	72,100 32,705	72,100 32,705	70,800 32,115	70,800 32,115	68,100 30,890	68,100 30,890														
12' 3.66 m	80,000 36,288	80,000 36,288	72,100 32,705	72,100 32,705	70,800 32,115	70,800 32,115	68,100 30,890	68,100 30,890	64,500 29,257	64,500 29,257												
15' 4.57 m	70,100 31,797	70,100 31,797	68,700 31,162	68,700 31,162	66,400 30,119	66,400 30,119	64,200 29,121	64,200 29,121	56,300 25,538	56,300 25,538	50,100 22,725	50,100 22,725										
20' 6.10 m	54,800 24,857	54,800 24,857	54,200 24,585	54,200 24,585	52,600 23,859	52,600 23,859	51,000 23,134	51,000 23,134	46,200 20,956	46,200 20,956	41,500 18,824	41,500 18,824	32,500 14,742	32,500 14,742								
25' 7.62 m	43,100 19,550	43,100 19,550	43,100 19,550	43,100 19,550	43,100 19,550	43,100 19,550	42,200 19,142	42,200 19,142	38,900 17,645	38,900 17,645	35,100 15,921	35,100 15,921	27,000 12,247	27,000 12,247	76°	22,200 10,070	22,200 10,070	77°	18,500 8,392	18,500 8,392		
30' 9.14 m			34,700 15,740	34,500 15,649	34,700 15,740	34,500 15,649	34,700 15,740	34,500 15,649	33,400 15,150	33,400 15,150	30,200 13,699	30,200 13,699	22,700 10,297	22,700 10,297	74°	22,200 10,070	22,200 10,070	75°	17,500 7,938	17,500 7,938		
35' 10.67 m					29,400 13,336	25,700 11,658	29,400 13,336	25,700 11,658	29,400 13,336	25,700 11,658	28,100 12,746	25,700 11,658	19,400 8,800	19,400 8,800	71°	20,200 10,070	20,200 10,070	72°	15,500 7,031	15,500 7,031		
40' 12.19 m					23,200 10,524	19,900 9,027	23,200 10,524	19,900 9,027	23,200 10,524	19,900 9,027	23,200 10,524	19,900 9,027	16,800 7,620	16,800 7,620	68°	18,900 8,573	18,900 8,573	70°	13,900 6,305	13,900 6,305		
45' 13.72 m							19,100 8,664	15,900 7,212	19,100 8,664	15,900 7,212	19,100 8,664	15,900 7,212	15,700 7,122	15,700 7,122	66°	17,300 7,847	17,300 7,847	67°	12,400 5,625	12,400 5,625		
50' 15.24 m							15,500 7,031	12,800 5,806	15,500 7,031	12,800 5,806	15,500 7,031	12,800 5,806	13,300 6,033	12,800 5,806	63°	15,400 6,985	15,100 6,849	64°	10,900 4,944	10,900 4,944		
55' 16.76 m								12,900 5,851	10,500 4,763	12,900 5,851	10,500 4,763	11,900 5,398	10,500 4,763	60°	14,300 6,486	12,700 5,761	62°	9,600 4,355	9,600 4,355			
60' 18.29 m									10,800 4,899	8,700 3,946	10,800 4,899	8,700 3,946	10,600 4,808	8,700 3,946	56°	12,900 5,851	10,700 4,854	59°	8,600 3,901	8,600 3,901		
65' 19.81 m									9,100 4,128	7,200 3,266	9,100 4,128	7,200 3,266	9,100 4,128	7,200 3,266	53°	11,100 5,035	9,200 4,173	56°	7,700 3,493	7,700 3,493		
70' 21.34 m										7,700 3,493	6,900 3,130	7,700 3,493	6,900 3,130	50°	9,700 4,400	7,900 3,583	53°	6,900 3,130	6,900 3,130			
80' 24.38 m											5,400 2,449	3,900 1,769	5,400 2,449	3,900 1,769	42°	7,400 3,357	5,900 2,676	46°	5,600 2,540	5,600 2,540		
90' 27.43 m												5,600 2,540	4,400 1,996	5,600 2,540	33°	5,600 2,540	4,400 1,996	39°	4,600 2,087	4,100 1,880		
100' 30.48 m													4,300 1,950	3,200 1,452	21°	4,300 1,950	3,200 1,452	30°	3,900 1,769	3,000 1,361		
110' 33.53 m																		17°	3,100 1,542	2,100 953		

## Wire rope size and type

Wire rope application	Size and type used	Wire rope description
Main winch Auxiliary winch	3/4" (19 mm) diameter, Type "N" 3/4" (19 mm) diameter, Type "N"	Type "N" - 6 x 25 (6 x 19 class) filler wire, extra improved plow steel, preformed, independent wire rope core, right lay, regular lay.

## Drum wire rope capacities

Wire rope layer	Main and auxiliary drum 17" (0.43 m) root diameter smooth and grooved lagging			
	3/4" (19 mm) wire rope			
	Rope per layer		Total wire rope	
	Feet	meters	Feet	meters
1	97	29.57	97	29.57
2	111	33.83	208	63.40
3	114	34.75	322	98.15
4	122	37.19	444	135.33
5	130	39.62	574	174.96
6	139	42.37	713	217.32
7	140	42.67	853	259.99

### Footnotes

- ① All capacities on outriggers are based on outriggers fully extended with boom sections extended equal distance
- ② Calculating capacities for extended or retracted boom plus fly must be based on boom angle only for boom lengths other than those listed. See Operating Instructions Number 14
- ③ See Operating Instructions, set-up Number 4

## Capacities On Tires

Load Radius	Max. boom length	Pick & Carry <sup>③</sup>	Stationary	
		Over Front	360°	Over Front
10' 3.05 m	35' 10.67 m	58,000 26,309	42,100 19,097	57,300 25,991
12' 3.66 m	35' 10.67 m	50,600 22,952	33,700 15,286	50,500 22,907
15' 4.57 m	35' 10.67 m	42,100 19,097	23,100 10,478	42,700 19,369
20' 6.10 m	35' 10.67 m	32,200 14,606	14,000 6,350	32,700 14,833
25' 7.62 m	35' 10.67 m	22,400 10,160	9,100 4,127	22,600 10,251
30' 9.14 m	40' 12.19 m	15,900 7,212	6,000 2,721	15,900 7,212
35' 10.67 m	40' 12.19 m	11,900 5,398	3,800 1,723	11,900 5,398
40' 12.19 m	48' 14.63 m	9,100 4,127	—	9,100 4,127
45' 13.72 m	56' 17.07 m	7,000 3,175	—	7,000 3,175
50' 15.24 m	56' 17.07 m	5,400 2,449	—	5,400 2,449
55' 16.76 m	62' 18.90 m	4,200 1,904	—	4,200 1,904
60' 18.29 m	72' 21.95 m	3,200 1,451	—	3,200 1,451

## HSP-8040 Lifting Capacities

35'-110' (10.67-33.53 m) 4-section boom

Refer to Operating Instructions page 4

Capacities <sup>①</sup> On Outriggers Manual Section Extended									
Load radius	105' (32.00 m)			110' (33.53 m)			110' (33.53 m) boom plus 33' (10.06 m) fly		
	Boom angle	Front	360°	Boom angle	Front	360°	Boom angle	Front	360°
	See Note <sup>②</sup>			See Note <sup>②</sup>			See Note <sup>③</sup>		
25' 7.62 m	76°	20,200 9 163	20,200 9 163	77°	19,000 8 618	19,000 9 027			
30' 9.14 m	73°	20,200 9 163	20,200 9 163	74°	18,500 8 392	18,500 8 392			
35' 10.67 m	71°	20,200 9 163	20,200 9 163	72°	17,300 7 847	17,300 7 847	76°	9,400 4 264	9,400 4 264
40' 12.19 m	68°	18,200 8 256	18,200 8 256	69°	14,800 6 713	14,800 6 713	74°	9,400 4 264	9,400 4 264
45' 13.72 m	65°	16,400 7 439	16,400 7 439	66°	13,300 6 033	13,300 6 033	72°	9,000 4 082	9,000 4 082
50' 15.24 m	62°	15,000 6 804	14,600 6 623	63°	11,600 5 262	11,600 5 262	70°	8,400 3 810	8,400 3 810
55' 16.76 m	59°	13,800 6 260	12,200 5 534	60°	10,200 4 627	10,200 4 627	68°	8,000 3 629	8,000 3 629
60' 18.29 m	55°	12,500 5 670	10,300 4 672	57°	9,100 4 128	9,100 4 128	66°	7,300 3 311	7,300 3 311
65' 19.81 m	52°	10,700 4 854	8,700 3 946	54°	8,200 3 720	8,200 3 720	64°	6,500 2 948	6,500 2 948
70' 21.34 m	48°	9,200 4 173	7,500 3 402	50°	7,400 3 357	7,400 3 357	61°	5,700 2 586	5,700 2 586
80' 24.38 m	39°	7,000 3 175	5,500 2 495	43°	6,100 2 767	5,400 2 449	56°	4,600 2 087	4,600 2 087
90' 27.43 m	29°	5,200 2 359	4,000 1 814	34°	4,600 2 087	3,900 1 769	51°	3,600 1 633	3,600 1 633
100' 30.48 m	12°	3,800 1 724	2,800 1 270	22°	3,800 1 724	2,700 1 225	46°	2,800 1 270	2,800 1 270
110' 33.53 m							39°	2,100 953	2,100 953
120' 36.58 m							32°	1,500 680	1,500 680

- ① All capacities on outriggers are based on outriggers fully extended with boom sections extended equal distance.
- ② Calculating capacities for extended or retracted boom with manual section extended must be based on boom angle only. See Operating Instructions Number 13.
- ③ Calculating capacities for extended or retracted boom with manual section extended plus fly must be based on boom angle only. See Operating Instructions Number 15.

Jib Capacities			
33' (8.84 m) fly plus 25' (7.62 m) jib			
Boom angle	Jib Offset		
	5°	17.5°	30°
78°	5,100 2 313	5,100 2 313	4,200 1 905
75°	5,100 2 313	5,100 2 313	4,000 1 814
70°	5,100 2 313	4,900 2 223	3,600 1 633
65°	4,500 2 041	4,100 1 860	3,400 1 542
60°	3,700 1 678	3,300 1 497	2,800 1 270
55°	3,000 1 361	2,700 1 225	2,400 1 089
50°	2,500 1 134	2,300 1 043	2,000 907

HSP-8040 hydraulic circuit pressure settings		
Circuit	Function	Pressure
Main	Boom hoist	2 900 p.s.i. (200.0 Bars)
	Wire rope hoist	2 750 p.s.i. (189.66 Bars)
Secondary	Swing	1 500 p.s.i. (103.45 Bars) at port relief*
	Innermid telescope Steering	2 500 p.s.i. (172.41 Bars)
	Outermid telescope	2 700 p.s.i. (186.21 Bars)
	Outriggers	2 700 p.s.i. (186.21 Bars)
Charge Pump	Winch brake and clutch	1 500 p.s.i. (103.45 Bars)

## Line Speeds and Pulls

Layer	Speed	Main or auxiliary winch -17" (0.43 m) drum			
		Line Speeds		Available Line Pulls	
		F.p.m.	m/min.	Lbs.	kgs.
First	Low	172	52.43	15,870	7 199
	High	364	110.95	7,520	3 411
Second	Low	187	57.00	14,630	6 636
	High	394	120.09	6,930	3 143
Third	Low	201	61.26	13,580	6 160
	High	425	129.54	6,430	2 917
Fourth	Low	216	65.84	12,660	5 743
	High	456	138.99	6,000	2 722
Fifth	Low	230	70.10	11,860	5 380
	High	487	148.44	5,620	2 549
Sixth	Low	245	74.68	11,160	5 062
	High	517	157.58	5,280	2 395
Seventh	Low	260	79.25	10,530	4 776
	High	548	167.03	4,990	2 264

## Tire Inflation

Tires	Ply	Pressure
21.0 x 25	24	85 p.s.i. (5.86 Bars)
26.5 x 25	24	75 p.s.i. (5.17 Bars)
29.5 x 25	22	60 p.s.i. (4.14 Bars)

# Warning and Operating Instructions

# HSP-8040

**General:**

1. Rated lifting capacities in pounds as shown on lift chart pertain to this machine as originally manufactured and normally equipped by Link-Belt Construction Equipment Company. Modifications to the machine or use of optional equipment other than that specified can result in a reduction of capacity.
2. Construction equipment can be dangerous if improperly operated or maintained. Operation and maintenance of this machine must be in compliance with the information in the operator's parts and safety manuals supplied with this machine. If these manuals are missing, order replacements through the distributor.
3. The operator and other personnel associated with this machine shall fully acquaint themselves with the latest applicable American National Standards Institute (ANSI) Safety Standards for cranes.
4. All capacities are in pounds with metric equivalent in italic.

**Set-Up:**

1. Capacities included in this chart are the maximum allowable crane capacities and are based on the machine standing level on firm supporting surface under ideal job conditions. Depending on the nature of the supporting surface, it may be necessary to have structural supports under the outrigger floats or tires to spread the load to a larger bearing surface.
2. When making lifts on outriggers, outrigger beams must be fully extended with tires free of supporting surface.
3. Eight parts of 3/4" (19 mm) diameter Type "N" wire rope required to lift maximum 80,000 lbs. (36 288 kg) rated load.
4. Crane Capacities on tires depend on tire capacity, condition of tires, and tire pressure. On-tire picks require lifting from main boom head only on a smooth and level surface. Pick and carry operations (creep), are restricted to 1.0 m.p.h. (1.61 km/h) with the boom centered over front, the travel swing lock engaged and the load restrained from swinging. Lifts with the manual extended, fly or fly/jib combination erected are prohibited.
5. When making lifts on rubber, tires must be inflated to the recommended pressure and power sections must be equally extended.

**Operation:**

1. Rated lifting capacities at rated radius shall not be exceeded. Do not tip the machine to determine allowable loads. For clamshell and concrete bucket operation, weight of bucket and load shall not exceed 80% of rated lifting capacities. Clamshell bucket weight including bucket content is restricted to a maximum of 7,000 pounds (3175 kg) with a maximum boom length of 56 feet (17.07 m) and a minimum boom angle of 35°. Manual extended, fly or fly/jib combinations are prohibited for clam work.
2. The crane capacities shown on outriggers do not exceed 85% of the tipping loads and crane capacities shown on tires do not exceed 75% of the tipping loads as determined by SAE crane stability test code J-765a. Those capacities above the heavy bold line indicate capacities based on factors other than those which would cause a tipping condition.

3. Do not operate at boom lengths or beyond radii where no capacities are shown. Machine may overturn without any load on the hook.
4. To determine capacities in-between those shown on charts, refer to the rated lifting capacity of the next longer and next shorter booms for the same radius. The lesser of the two capacities will apply.
5. When making lifts at a load radius not shown on charts, use the next longer radius to determine allowable capacity.
6. Crane capacities are based on freely suspended loads and make no allowance for such factors as the effect of wind, sudden stopping of loads, supporting surface conditions, inflation of tires, and operating speeds. Operator must reduce load ratings to take such conditions into account. Deductions from rated capacities must be made for weight of hook block, weighted ball/hook, sling, spreader bar, fly or other suspended gear.
7. Rated lifting capacities are based on correct reeving. Deduction must be made for excessive reeving. Any reeving over minimum required is considered excessive and must be taken into account. Use working range plate to estimate the extra feet of rope and then deduct 1 lb. (4536 kg) for each foot of wire rope before attempting to lift a load.
8. The following deductions from rated main boom capacities must be made if the machine is equipped with the following:
  - a. auxiliary lifting sheave - 200 lbs. (91 kg.)
  - b. 33' (10.06 m) one-piece fly stowed on boom - 700 lbs. (318 kg)
  - c. 33' (10.06 m) one-piece fly in working position - 1,800 lbs. (816 kg)
  - d. 33' (10.06 m) fly plus 25' (7.62 m) jib stowed on boom - 1,100 lbs. (499 kg)
  - e. 33' (10.06 m) fly plus 25' (7.62 m) jib in working position - 4,400 lbs. (1 996 kg)
  - f. 25' (7.62 m) jib in working position and picking from fly tip - 1,900 lbs. (862 kg)
9. Powered boom length is from 35' (10.67 m) to 85' (25.91 m).
10. Extension or retraction of the boom with loads within the limits of the applicable rating chart may be attempted. The ability to telescope loads is limited by hydraulic pressure, boom angle, boom length, boom lubrication, etc.
11. Do not move load to radii or boom lengths greater than those specified on applicable chart.
12. Effective length of boom with auxiliary lifting sheave is length shown on boom length indicator plus 2' (0.61 m).
13. The rated loads for the manual extended are determined by boom angle only for boom lengths other than 105' (32.00 m) and 110' (33.53 m) as follows: For boom lengths less than 105' (32.00 m), the rated loads are determined by boom angle only in the column headed 105' (32.00 m). For boom lengths between 105' (32.00 m) and 110' (33.53 m), the rated loads are determined by boom angle only in the column headed 110' (33.53 m) manual extended. For angles not shown, use next lower: boom angle to determine allowable capacity.

14. The rated loads for the manual retracted with 33' (10.06 m) fly are determined by boom angle only for boom lengths other than 110' (33.53 m) and 118' (35.97 m) as follows: For boom lengths with fly and manual retracted less than 110' (33.53 m), the rated loads are determined by boom angle only in the column headed 110' (33.53 m) manual retracted with fly. For boom lengths with fly and manual retracted between 110' (33.53 m) and 118' (35.97 m), the rated loads are determined by boom angle only in the column headed 118' (35.97 m). For angles not shown, use the next lower boom angle to determine allowable capacity.
15. For boom lengths with fly less than 143' (44 m) with manual extended, the rated loads are determined by boom angle only in the column headed 143' (44 m). For angles not shown, use the next lower boom angle to determine allowable capacity.
16. The 25' (8 m) jib capacities are based on main boom angle, regardless of main boom length. For angles not shown, use next lower boom angle to determine allowable capacity. Capacity values are for 360 degree operation. Warning: Do not lower 25' (8 m) jib in working position below 50 degrees unless boom is fully retracted.
17. The 35' (10.67 m) boom length capacities are based on boom fully retracted. If not fully retracted, do not exceed ratings for the 40' (12.19 m) boom length.

**Definitions:**

1. Load Radius: Horizontal distance from a projection of the axis of rotation to the supporting surface before loading to the center of the vertical hoist line or tackle with load applied.
2. Loaded Boom Angle: The angle between the boom base section and the horizontal after lifting the load at the rated radius. The boom angle, before loading, should be greater to account for deflections.
3. Working Area: Area measured in a circular arc about the center line of rotation as shown on the working area diagram.
4. Freely Suspended Load: Load hanging free with no direct external force applied except by the hoist line.
5. Side Load: Horizontal side force applied to the lifted load either on the ground or in the air.

## Working Areas

## HSP-8040

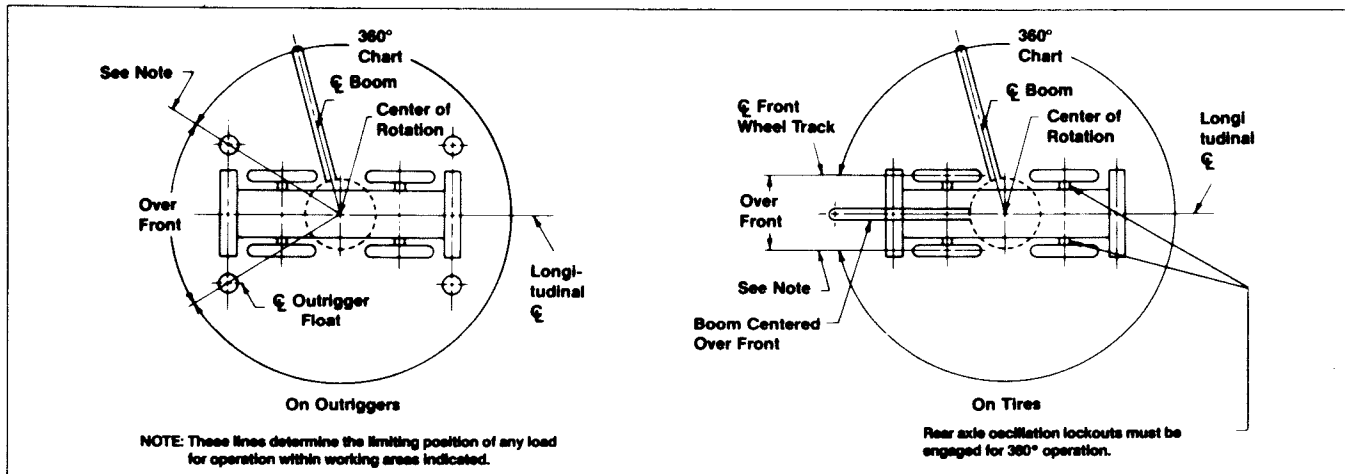

We are constantly improving our products and therefore reserve the right to change designs and specifications.

\* Link-Belt is a registered trademark.

