

HTC-8650 50-ton

Telescopic Truck Crane

- 110' (33.53 m) Full Power 4-Section Boom
- 172' (52.43 m) On-Board Tip Height
- Two Powertrain Options
- Two Attachment Options



The New HTC-8650 Features The
Confined Area Lifting Capacities
(CALC™) System



• Loaded With Advances...Not Compromises •

• COMFORT • CONTROL •

Maximum Comfort and Control...standard operating values on the HTC-8650 with its revolutionary fibrous composite cab – the ULTRA-CAB™, gear motor winches, and integral rated capacity limiter (RCL).

An Office With A View....

A major step forward in the construction equipment industry, the new environmental ULTRA-CAB found on the HTC-8650 is molded from an LFC•2000 construction process featuring laminated fibrous composite material. Laminated fibrous composites are a hybrid class of composites with lamination techniques. The layers of fiber-reinforced material are built up with the fiber directions of each layer typically oriented in different directions to add strength and stiffness.

This fibrous composite technology offers superior advantages over steel in sound reduction with sound levels one-half as loud as conventional cabs. This fibrous composite material, while eliminating corrosion, also adds dimensional stability and allows modern styling techniques to be utilized including molded radii and ribs. Designed with the operator in mind, the cab features:



Fabric Seat New improved six-way adjustable seat with height-adjustable armrests and 45° reclining seat back.

Hydraulic Control Levers Armrest mounted, responsive dual axis controllers standard. Single axis available.

Lift-Up Armrest Left armrest lifts up out of the way providing outstanding operator ease in entering or exiting the cab. For safety, all control functions become inactive when the armrest is in raised position.

Overhead Console with switches for outrigger controls, lights, fan,

windshield wiper, function lockout, swing park brake, and ignition.

Bubble Level Sight level mounted on side console.

Single Foot Pedal Control Hydraulic pilot controlled for simultaneous extension or retraction of power boom sections.

Ducted Air through automotive style directional vents.

Comprehensive Instrumentation Corner post mounted backlighted gauges monitor hydraulic oil temperature, fuel level, coolant temperature, oil pressure and voltage. Corner post also has stop engine and check engine indicator lights and tachometer.

Additional Cab Features Include:

- Dash-less design for superior visibility.
- Automotive style windshield and large side window provides operator with 25% more glass area.
- Sliding right side and rear windows and swing-up roof window provide excellent ventilation.
- Large sweep electric wipers.

Integral Rated Capacity Limiter

This "LMI" system aids the operator in safe and efficient operation by continuously monitoring boom length, boom angle, head height, radius of load, machine configuration, allowed load, actual load, and percent of allowed load. This Microguard 434 graphic audio-visual system features improved access time, improved radio frequency shielding, a new display panel with large liquid crystal alphanumeric display, total system override capabilities to provide for rigging requirements and an expanded memory which provides capacity information on all possible lift configurations.



An exclusive new feature available on the HTC-8650 is the Operator Defined Area Alarm. By setting two points, the operator creates an imaginary vertical plane to maintain a safe working distance from nearby obstacles. Should the operator attempt to operate the crane beyond the plane, the RCL will sound an alarm.

An optional graphic display bar, positioned near the top of the windshield for optimum viewing during crane operation, is available. This bar constantly alerts the operator of the current lift capacity situation through a series of green (within capacity range), yellow (approaching 90% chart limit), and red (100% of chart limit) lights.

State-of-the-Art Wire Harness

The HTC-8650 with its multi-plex gauge package has automotive-type wire harnesses with sealed relays and connectors throughout for outstanding long term reliability. In addition, all wires have a

flame retardant, polyethylene insulation, resulting in a higher heat resistant wiring system.

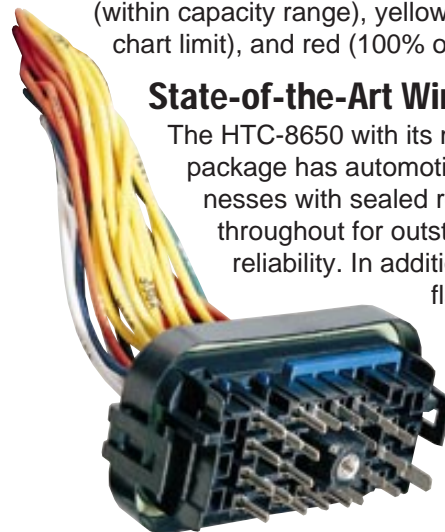

POWER • PRODUCTIVE

Link-Belt has never been content simply to build cranes the same way as everyone else...the new HTC-8650 proves that again.

With 172' (52.43 m) of on-board tip height, superior capacities, innovative engineering, attachment flexibility, and available counterweight lowering for balanced axle loadings for travel, this crane is loaded with advances instead of compromises.

Transportability

The HTC-8650 offers superior roadability complete with 172 ft. (52.43 m) of on-board tip height. Transportability is enhanced by the unique counterweight design. In addition to the standard 5,000 lb. (2 268 kg) counterweight, two 3,000



lb. (1 361 kg) slab-type counterweight pieces and counterweight lowering are available. This hydraulic removal system can position one or both of these counterweight slabs on the carrier deck for most efficient axle load distribution or can lower them directly

onto a trailer for transport. Counterweight removal cylinders are recessed in the upper frame for protection.

Wide Stance Carrier An 8' 6" (2.59 m) wide carrier with 231" (5.87 m) wheelbase provides 'big feet' for a stable lifting base. The Link-Belt 8 x 4 carrier features:

- Large strategically located grab handles/steps and mid-mount access ladders provide superior accessibility to carrier deck areas and engine for routine maintenance and service.
- Flat deck area.
- Lightweight aluminum outrigger floats with a "quick latch" feature.
- Throttle-up switch at outrigger control station.
- Self-storing fifth outrigger steel pontoon.
- Full air, S-cam brakes on all wheel ends with automatic slack adjusters.
- Rack and pinion steering puts the operator in complete control. This two steering gear system does not have exposed machined surfaces which can be easily damaged by rocks and debris.
- Air service ports.
- Complete DOT approved light package including side mounted clearance/turn indicator lights.
- Aluminum fuel tank for less condensation and corrosion.

Power Train Utilization of a Detroit Diesel Series 50 engine and Eaton transmission translates to maximum parts availability as these components are common to the construction and on-highway truck industry. The Detroit Diesel 315 horsepower (235 kW) engine, coupled to the

11-speed forward, 3-speed reverse transmission, features electronic throttle control and cruise control. The 8650 can travel at a .5 mph (.80 km/hr) creep speed @ idle for maximum maneuverability on the job site and run up to 58 mph (93 km/hr) top speed on the highway, unmatched in the industry today. If "more power" is what you desire, an optional 365 horsepower Detroit Diesel Series 60 engine is available.

Carrier Cab The carrier cab and engine cowling are also manufactured from laminated fibrous composite material which is combined with acoustical treatments to assure the operator of maximum highway comfort.



Additional features include dash mounted comprehensive instrumentation with attractive lighted gauges, sliding side and rear windows and roll up/down door window for excellent ventilation, fully adjustable air ride fabric seat, suspended pedals, and rear view mirrors. Cruise control and engine brake controls are conveniently located on transmission shift lever.

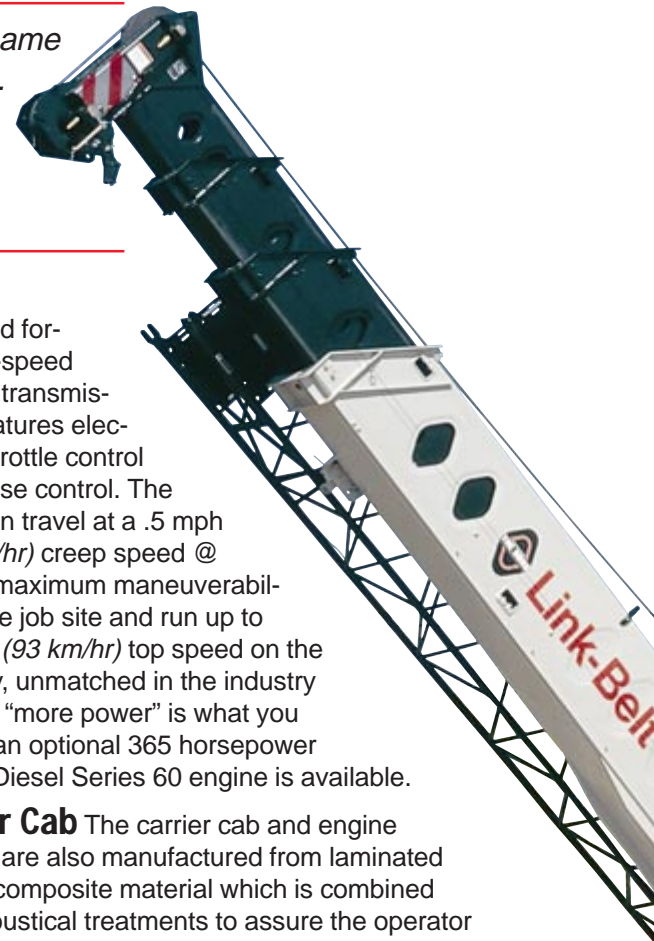

V I T Y • R E L I A B I L I T Y

Paint Coating System Link-Belt utilizes a two-part coating technology coupled with a pre-assembly paint process to provide the finest quality coating system available today. This new coating technology provides superior adhesion and abrasion resistance. Because all parts are painted before assembly, 100% coverage of each part is realized, virtually eliminating corrosion bleed-through that is common with other paint processes.

Serviceability Wide opening engine doors provide excellent accessibility, fittings are staggered for easy servicing, and standard quick disconnects installed at various locations in the hydraulic system allow the hydraulic pressure to be quickly and easily checked with Link-Belt's exclusive diagnostic kit (optional). The driver can use the stop engine and check engine indicator lights to troubleshoot the engine. An engine diagnostic connector, located under the carrier cab dash, allows an engine service technician to further analyze engine problems with an engine diagnostic data reader.

Gear Motor Hydraulic Hoist System

The standard load hoist system consists of:

- 2M main winch with two-speed motor and automatic brake for power up/down mode of operation.
- Asynchronous, parallel double cross-over grooved drums minimize rope harmonic motion, improving spooling and increasing rope service life.
- Standard rotation resistant rope.
- An available two-speed 2M auxiliary winch. On the two-winch machines, an independent winch function lockout is provided. When this mode is selected, the operator won't inadvertently operate a winch which has been shut down preventing a two blocking or rope "bird nesting" situation.

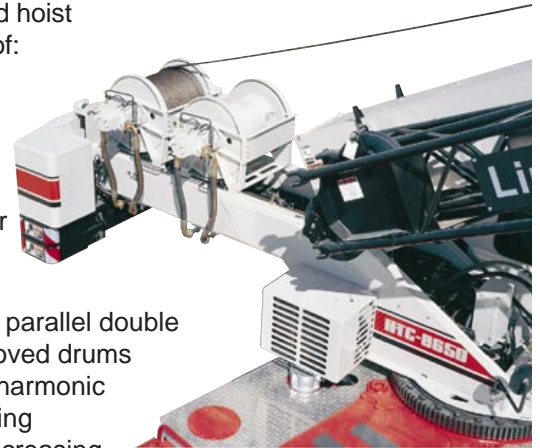

Multi-Function Control For greater productivity and control, the five pump-section hydraulic circuit provides smooth, simultaneous function of winch, boomhoist, swing, and drums.

State-Of-The-Art Oil Seal Technology

The HTC-8650 features improved seals on boomhoist, boom extend/retract, and outrigger jack cylinders. This new 'redundant' oil seal technology incorporates 3 rod sealing surfaces versus one or two found on competitive models. This new seal design is highly resistant to side loading and pressure spikes for outstanding sealing performance and when incorporated with full O-ring face seal technology used throughout the machine, leads to an environmentally dry system.

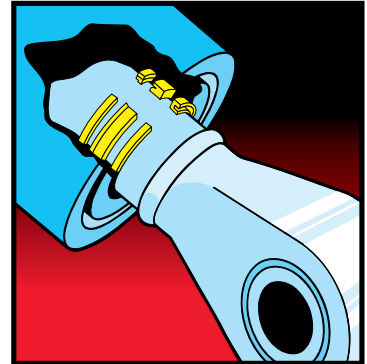

Computer-Aided Design

Advanced, high speed computer-aided, state-of-the-art designs are measured by their reliable performance through extensive testing and re-testing before Link-Belt endorses a new idea, assuring the customer of real user value and maximum on-the-job performance.



• I N N O V A T I O N S •

The New HTC-8650 telescopic truck crane features unmatched innovations such as the Confined Area Lifting Capacity System (CALC™) and two modes of boom extension...innovative design features that have become industry standards from Link-Belt.



Retracted Outriggers
7' 9" (2.36 m) Spread



Intermediate Outriggers
14' 2" (4.32 m) Spread



Fully Extended Outriggers
20' 6" (6.25 m) Spread

Confined Area Lifting Capacities (CALC™)

The HTC-8650 is specifically designed to allow contractors to work in confined work areas where full outrigger extension is not possible. The CALC system provides the operator with three outrigger positions (full extension, intermediate, and retracted). Outriggers may be extended to an intermediate position where working area is limited or, in extremely tight quarters, lifts can be made with outriggers fully retracted. In the fully retracted outrigger mode, lift capacities are significantly improved over the 'on tires' configuration. When the **extend position pins**, located on top of the outrigger boxes, are engaged, the operator can set the crane in the intermediate or fully retracted outrigger mode without having to leave the cab. A thorough, easy-to-read crane rating manual gives the operator comprehensive capacities covering the three outrigger positions, five counterweight configurations, and all attachments plus 'on tires' capacities.

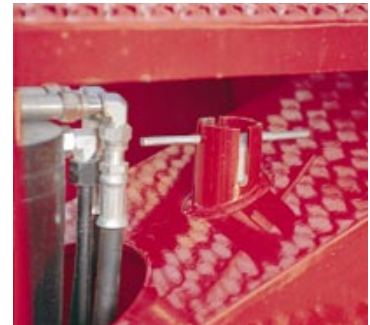

4-Section Full Power Boom With *A*-max Mode

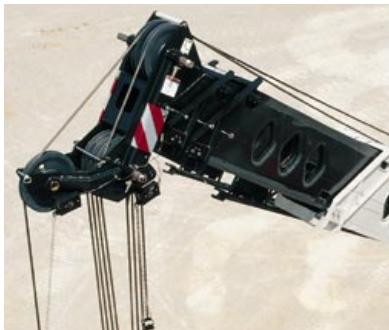

Exclusive *A*-max boom extend mode



Basic boom extend mode – boom mode 'B'

Two standard boom extension modes enhance the 8650's performance and provides the operator the capability to match the crane's configuration to specific jobsite conditions. For maximum tip height the basic boom extension mode (mode 'B') offers a full power, synchronized mode of telescoping all sections proportionally to 110' (33.53 m). To enhance performance, the exclusive *A*-max mode (or mode 'A') extends only the inner mid section to 60.3' (18.38 m) offering substantially increased capacities for in-close, maximum capacity picks.

• PATENTED BOOM •

EXCLUSIVE



Embossed Sidewall Stiffeners With No-Weld Corners

Boom Concept The arrangement of high strength angle chords (corners) with high formability steel sidewall (embossments) places the most steel at corners where maximum stress is concentrated. The result: maximum strength with minimum weight.

Embossed Sidewall Stiffeners Increases sidewall stiffness.

Sidewall Design Concept Not only do the embossments increase sidewall stiffness, but because of their placement they naturally transfer stresses uniformly to the high strength angle chords (corners) — a concept derived from Link-Belt lattice boom technology.

Boom Wear Shoes Boom wear shoes are replaceable without boom disassembly and utilize simple fast external adjusters.

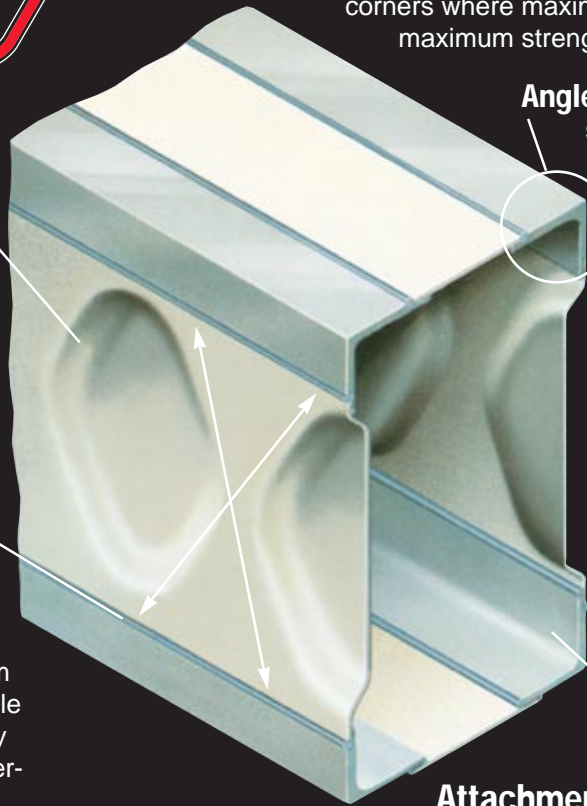

Angle Chords 100,000 psi (689.5 MPa) high strength steel angle chords are precision machined for boom sidewall overlap. This design allows all interior and exterior boom welds to be offset or staggered for maximum structural integrity.

Time Proven Boom Design Over two decades and thousands of hydraulic crane booms later, Link-Belt's exclusive, patented design is unchanged, state-of-the-art — before its time; providing superior capacities, tip heights and reliability.

It is true testimony to Link-Belt's engineering design achievement that this design concept is being imitated today for optimum performance.

NO WELDS IN HIGH STRESS CORNERS

Attachment Flexibility

- Full power, fully synchronized 35' 6" – 110' (10.82 – 33.53 m) four-section boom.
- Stowable, 34' (10.36 m) offsettable (1°, 15°, or 30° offset), one piece lattice type fly with lugs to allow addition of second section.
- Stowable, 34' – 56' (10.36 m – 17.07 m) offsettable (1°, 15°, or 30° offset) 2-piece, double swing-around, lattice type fly.

Added Value Attachment Features

- **Fast, Easy, Fly Pinning** The fly pinning tool helps eliminate the age old problem of difficult fly pin alignment and pin installation.
- **Quick Reeve Head Machinery** for fast, easy parts of line change.
- **Hammerhead Boom Nose** Allows the operator to work at high boom angles without fouling wire rope.
- **Deflector Rollers** Rollers prevent premature wire rope wear when working at low boom angles.
- **Lightweight Nylon Head Sheaves** Reduce overall machine weight and increases lift capacities.
- **Available Auxiliary Lifting Sheave** Can be used for quick lifts with one or two parts of line when the boom head has multiple reeving. And it does not have to be removed when fly is erected in working position.



Stowable Attachments Swing-away lattice flies are easily stored for transportability or can be removed to meet specific road laws.

Authorized Link-Belt Distributor

Link-Belt Construction Equipment Company Lexington, Kentucky

A unit of Sumitomo Construction Machinery Co., Ltd. www.linkbelt.com

© Link-Belt is a registered trademark. We are constantly improving our products and therefore reserve the right to change designs and specifications. Copyright 1998. Litho in U.S.A. 4/98

#4216

Specifications

Telescopic Boom Truck Crane

HTC-8650

50-ton (45.36 metric tons)

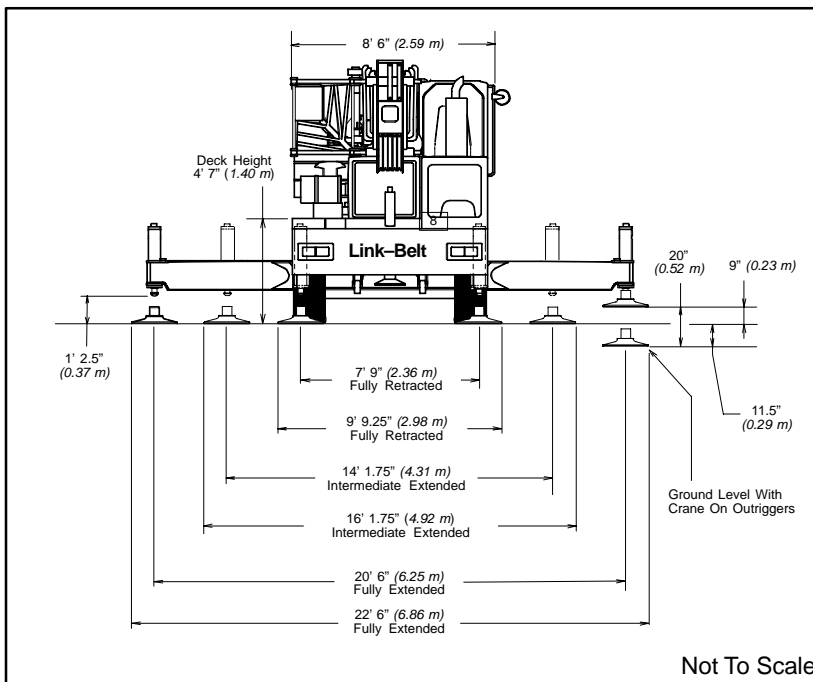
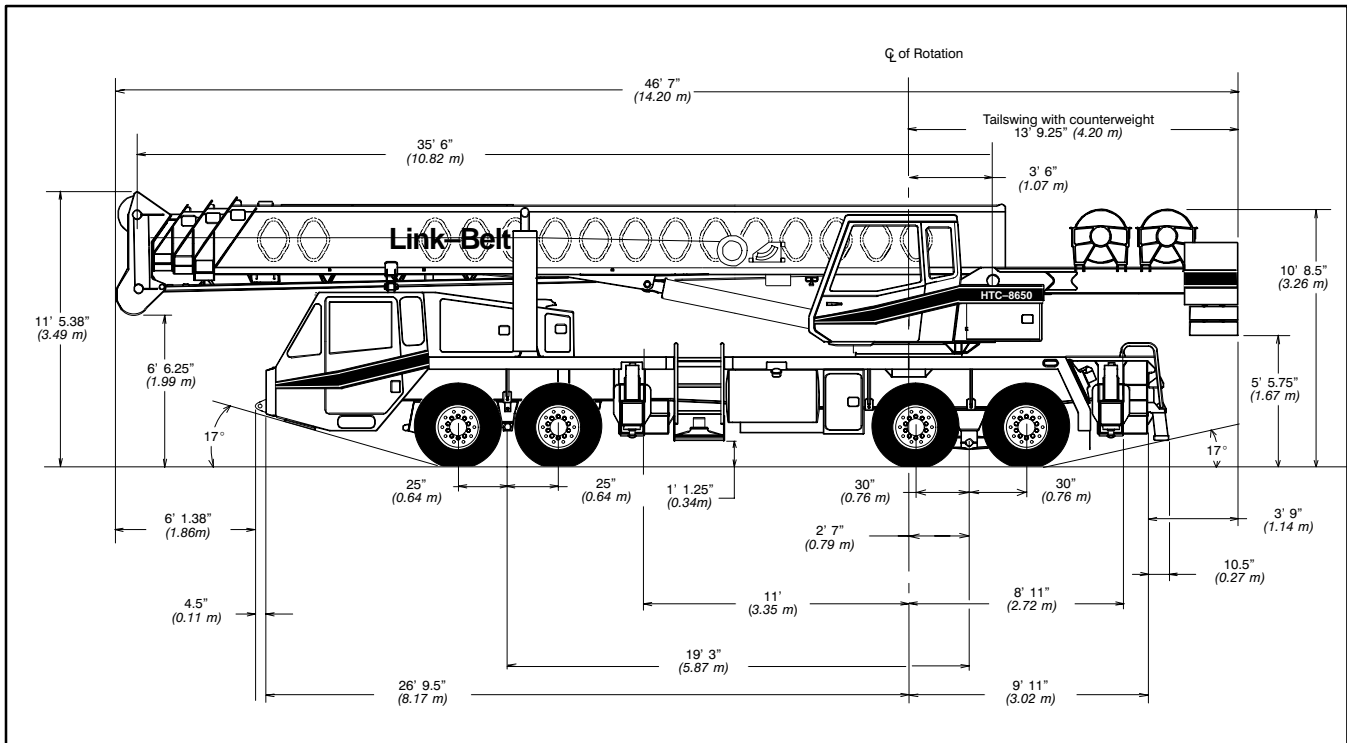

General Dimensions	feet	meters
Turning radius – wall to wall	45' 10"	13.97
Turning radius – curb to curb	38' 10"	11.84
Ground clearance	13.25"	0.34
Tailswing	13' 9.25"	4.20

Upper Structure

■ Boom

Patented Design

- Boom side plates have diamond shaped impressions for superior strength to weight ratio and 100,000 p.s.i. (689.5 MPa) steel angle chords for lateral stiffness.
- Boom telescope sections are supported by top, bottom and adjustable side wear shoes to prevent metal to metal contact.

Boom

- 35.5' – 110' (10.82 – 33.53 m) four-section full-power boom
- Two mode boom extension
- The basic mode is the full power, synchronized mode of telescoping all sections proportionally to 110' (33.53 m).
- The exclusive "A-max" mode (or mode 'A') extends only the inner mid section to 60.3' (18.38 m) offering increased capacities for in-close, maximum capacity picks.
- Mechanical Boom Angle Indicator

Boom Head

- Four 16.5" (0.42 m) root diameter nylon sheaves to handle up to eight parts of wire rope.
- Easily removable wire rope guards
- Rope dead end lugs provided on each side of boom head.
- Boom head designed for quick reeve of hook block.
- Fifth head sheave is optional

Boom Elevation

- Two Link-Belt designed hydraulic cylinders with holding valves and bushings in each end.
- Hand control for controlling boom elevation from -3° to +78°.

Optional Auxiliary Lifting Sheave

- Single 16.5" (0.42 m) root diameter nylon sheave with removable wire rope guard, mounted to boom.
- Use with one or two parts of line off the optional front winch.
- Does not affect erection of fly or use of main head sheaves for multiple reeving.

Optional

- 40-ton (36.3 mt) quick-reeve hook block
- 60-ton (54.43 mt) quick-reeve hook block
- 70-ton (63.30 mt) quick-reeve hook block
- 8.5-ton (7.71 mt) hook ball
- Boom floodlight

■ Fly

Optional

- 34' (10.36 m) one-piece lattice fly, stowable, offsettable to 2°, 20° and 40°
- 34' – 56' (10.36 – 17.07 m) two-piece (bi-fold) lattice fly, stowable, offsettable to 2°, 20° and 40°

■ Cab and Controls

Environmental Ultra-Cab™

- Laminated fibrous composite material; isolated from sound with acoustical fabric insulation.

- Windows are tinted and tempered safety glass
- Sliding rear and right side windows and swing-up roof window for maximum visibility and ventilation.
- Slide-by-door opens to 3' (0.91 m) width.
- Six-way adjustable seat, with seat belt, for maximum operator comfort.
- Hand held outrigger controls and sight level bubble located in cab.
- Top hatch window wiper
- Audible swing alarm
- Fire extinguisher
- Sun screen
- Electric windshield wiper
- Windshield washer
- Cab work lights
- Pull-out Cabwalk™

Optional

- Amber strobe light
- Third wrap indicator
- Amber rotating beacon
- Diesel or hydraulic heater
- RCL light bar
- Air conditioning

Controls

Hydraulic controls (joystick type) for:

- Swing
- Optional auxiliary winch
- Main winch
- Boom hoist

Foot controls for:

- Boom telescope
- Swing brake
- Engine throttle

Optional

- Auxiliary winch
- Single axis controls

Cab Instrumentation

Cornerpost-mounted gauges for:

- Hydraulic oil temperature
- Audio/Visual warning system
- Check and stop engine indicator lights
- Tachometer
- Voltmeter
- Water temperature
- Oil pressure
- Fuel

■ Rated Capacity Limiter

- **Microguard 434** Graphic audio-visual warning system built into dash with anti-two block and function limiters.

Operating data available includes:

- Machine configuration.
- Boom length
- Head height
- Allowed load
- % of allowed load
- Boom angle
- Radius of load
- Actual load

Presetable alarms include:

- Maximum and minimum boom angles
- Maximum tip height
- Maximum boom length
- Swing left/right positions
- Operator defined area alarm is standard
- Anti-two block weight designed for quick reeve of hookblock

Optional

- **Internal RCL light bar:** Visually informs operator when crane is approaching maximum load capacity with a series of green, yellow and red lights.

- **External RCL light bar:** Visually informs ground crew when crane is approaching maximum load capacity kickouts and pre-settable alarms with a series of three lights; green, yellow and red.

■ Swing

- Bi-directional hydraulic swing motor mounted to a planetary reducer for 360° continuous smooth swing at 2.2 r.p.m.
- **Swing park brake** – 360°, electric over hydraulic (spring applied, hydraulic released) multi-disc brake mounted on the speed reducer. Operated by toggle switch in overhead control console.
- **Swing brake** – 360°, foot operated, hydraulic applied disc brake mounted on the speed reducer.
- **Swing lock** – Standard; two position travel lock (pin device) operated from the operator's cab.
- **Counterweight**
 - Standard – Bolted to upper structure frame. 11,000 lbs. (4 990 kg) three piece design. Consist of one 5,000 lbs. (2 268 kg) piece bolted to upper structure and two 3,000 lbs. (1 361 kg) pieces pinned to standard counterweight.
 - Two counterweight sections can be hydraulically lowered on, and pinned to carrier deck to balance axle loadings for travel.
- **Optional**
 - 360° swing lock. Meets New York City requirements
 - 6,000 lbs. (2 722 kg) counterweight

■ Hydraulic System

Main Pump

- One gear pump with a total of four sections
- Combined pump capacity of 176 gpm (666 lpm)
- Powered by carrier engine with pump disconnect
- Rocker switch controlled, air applied pump disconnect engaged / disengaged from carrier cab.
- Maximum system operating pressure is 3,000 psi (20 685 kPa).
- O-ring face seals technology used throughout with hydraulic oil cooler standard.

Pilot Pressure / Counterweight Removal Pump

- Pressure compensated piston pump powered by carrier engine. Max pump operating pressure is 1,500 psi (10 342 kPa).

Steering / Fifth Outrigger Pump

- Single gear type pump, 8 gpm (30 lpm). Powered by carrier engine through front gear housing.
- Maximum pump operating pressure is 2,000 psi (13 790 kPa).

Reservoir

- 169 gallon (639.7 L) capacity. One diffuser for deaeration.

Filtration

- One 10-micron filter located inside hydraulic reservoir.
- Accessible for easy replacement

Control valves

- Six separate pilot operated control valves allow simultaneous operation of all crane functions.

Load Hoist System

Standard

- 2M main winch with grooved lagging

- Two-speed motor and automatic brake
- Power up/down mode of operation
- Bi-directional gear-type hydraulic motor driven through planetary reduction unit for positive control under all load conditions.
- Asynchronous parallel double crossover grooved drums minimize rope harmonic motion.
- Pressure compensated winch circuit provides balanced oil flow to both winches for smooth, simultaneous operation.
- Rotation resistant wire rope
- Drum rotation indicators

Line Pulls and Speeds

- Maximum available line pull 16,407 lbs. (7 442 kg) and maximum line speed of 463 f.p.m. (141 m/min) on 16" (0.41 m) root diameter grooved drum.

Optional

- 2M auxiliary winch with two-speed motor, automatic brake, and winch function lock-out. Power up/down modes.
- Third wrap indicators

Carrier

Type

- 8' 6" (2.59 m) wide, 231" (5.87 m) wheel-base. 8 x 4 drive – standard.

Frame

- 100,000 p.s.i. (689.5 MPa) steel, double walled construction with integral 100,000 p.s.i. steel outrigger boxes.

Optional

- Carrier mounted storage boxes
- Pintle hook
- Electric and air connections for trailers and boom dollies

Axles

Front

- Single, 83.72" (2.13 m) track

Rear

- Tandem, 72.8" (1.85 m) track. 6.17 to 1.0 ratio with interaxle differential with lockout.

Suspension

Front axle

- Leaf spring suspension

Rear axle

- Air-ride, bogie beam type, suspension.

Wheels

Standard

- Hub piloted steel disc

Optional

- Hub piloted aluminum disc
- Spare tire and wheel assemblies

Tires

Standard Front

- 425/65R22.5 (Load range "L") single tubeless radials

Standard Rear

- 12R22.5 (Load range "H") dual tubeless radials

Optional

- 445/65R22.5 (Load Range "L") Single tubeless radials front 12R22.5 (Load range "H") dual tubeless radials rear – mounted on steel disc wheels front/rear.

Brakes

Service

- Full air brakes on all wheel ends with automatic slack adjusters. Dual circuit with modulated emergency brakes.
- Front – 16.5 x 6 S-Cam brakes
- Rear – 16.5 x 7 S-Cam brakes

Parking/Emergency

- One spring set, air released chamber per rear axle end.
- Parking brake applied with valve mounted on carrier dash.
- Emergency brakes apply automatically when air drops below 60 psi (413.7 kPa) in both systems.

Steering

- Sheppard rack and pinion design

Transmission

Standard

- Eaton RTO 11909ALL; 11 speeds forward, 3 reverse with Series 50 engine.

Optional

- Eaton RTO-14909ALL; 11 speeds forward, 3 reverse with Series 60 engine.

Electrical

- Two 12-volt batteries provide 12-volt starting. 130-amp alternator
- 2,800 cold cranking amps available
- 12-volt operating system

Lights

- Four dual beam sealed headlights
- Front, side, and rear directional signals
- Stop, tail and license plate lights
- Rear and side clearance lights
- Hazard warning lights

Outriggers

- Three position operation capability.
- Four hydraulic, telescoping beam and jack outriggers.
- Vertical jack cylinders equipped with integral holding valve.
- Beams extend to 20' 6" (6.25 m) centerline-to-centerline and retract to within 8' 6" (2.59 m) overall width.
- Equipped with stowable, lightweight 24" (0.61 m) diameter aluminum floats.
- Standard fifth outrigger, 14 3/4" (0.37 m) self storing steel pad is operable from ground or operator's cab.
- Hand-held controls and sight level bubble located in operators cab and on carrier deck.

Confined Area Lifting Capacities (CALC™) System

- The crane is operational in one of the three outriggers positions and operational in confined areas in two positions (intermediate and full retraction).

The three outrigger positions are:

- Full extension – 20' 6" (6.25 m)
- Intermediate position – 14' 1.75" (4.31 m)
- Full retraction – 7' 9" (2.36 m)
- Capacities are available with the outrigger beams in the intermediate and full retraction positions.
- When the outrigger position levers (located on the outrigger beams) are engaged, the operator can set the crane in the intermediate or full retraction outrigger position without having to leave the cab.

Carrier Cab

- One-man cab of laminated fibrous composite material acoustical insulation with cloth covering. Equipped with:
- Air-ride, six-way adjustable operator's seat.
- Four-way adjustable tilting and lockable steering wheel.
- Door and windows locks
- Left-hand and right-hand rear view mirrors.
- Sliding right-hand and rear tinted windows.
- Roll up/down left-hand tinted window.
- Desiccant-type air dryer
- Steps to upper, lower cab and rear carrier
- 110-volt electric engine block heater
- Back-up warning alarm
- Tow hooks and shackles
- Aluminum fenders with ground control outriggers.
- Electric windshield wiper and washer
- Travel lights
- Fire extinguisher
- 36,000 BTU heater
- Dome light
- Mud flaps
- Horn
- Ashtray
- Defroster
- Cruise control

Optional

- Air conditioning
- Amber strobe light
- Rotating beacon

Cab instrumentation

- Illuminated instrument panel speedometer.
- Tachometer
- Fuel gauge
- Oil pressure gauge
- Turn signal indicator
- Water temperature gauge
- Front and rear air pressure gauges
- Audio/visual warning system
- Automotive type ignition
- Hourmeter
- Fuses
- Odometer
- Voltmeter

Carrier Speeds (Manual Transmission – Standard tires)

Gear	High				Low				Deep reduction		Hi rev.	Lo rev.	Deep reduction	Deep reduction @ 700 rpm	Deep reduction @ 700 rpm		
	8	7	6	5	4	3	2	1	Low	LL2	LL1	Rev	Rev	Rev.	LL1	Low	
Ratio	0.73	1.00	1.38	1.95	2.77	3.79	5.23	7.41	16.30	11.85	26.08	3.43	13.03	20.85	26.08	20.85	
Speed	mph	58.20	42.49	30.79	21.79	15.34	11.21	8.12	5.73	2.61	3.59	1.63	12.13	3.19	1.99	0.55	0.66
	km/hr.	93.65	68.36	49.54	35.06	24.68	18.04	13.07	9.23	4.19	5.77	2.62	19.52	5.13	3.20	0.88	1.06

Engine

Engine – standard	Detroit Diesel, Series 50 8.5 L	Engine – optional	Detroit Diesel, Series 60 12.7 L
Cylinders – cycle	6 / 4	Cylinders – cycle	6 / 4
Bore	5.12" (0.13 m)	Bore	5.12" (0.13 m)
Stroke	6.30" (0.16 m)	Stroke	6.30" (0.16 m)
Displacement	519 cu. in. (8 506 cm ³)	Displacement	778 cu. in. (12 751 cm ³)
Maximum brake hp.	315 @ 1,800 rpm; 315 @ 2,100 rpm	Maximum brake hp.	365 @ 1,800 rpm; 350 @ 2,100 rpm
Peak torque	1,150 ft. lbs. (1 560 J) @ 1,200 rpm	Peak torque	1,350 ft. lbs. (1 831 J) @ 1,200 rpm
Electric system	12-volt neg. ground / 12-volt starting	Electric system	12-volt neg. ground / 12 volt starting
Fuel capacity	100 gallons (378.5 L)	Fuel capacity	100 gallons (378.5 L)
Alternator	12 volt, 130 amps	Alternator	12 volt, 130 amps
Crankcase capacity	22 qts. (21 L)	Crankcase capacity	32 qts. (30 L)
		• Engine brake – standard	• Ether injection starting package – optional

Axle Loads

Base machine with standard 35.5' – 110' (10.82 – 33.53 m) four-section boom, 2M main winch with 2-speed hoisting and power up/down, 600' (182.88 m), 3/4" (19 mm) wire rope, 8 x 4, 8.5' (2.59 m) carrier with Detroit Diesel Series 50 8.5 L engine, 100 gal. (378.5 L) fuel, steel fenders and 5,000 lb. (2 268 kg.) counterweight.	G.V.W. ¹		Upper Facing Front			
			Front Axle		Rear Axle	
		lbs.	kg.	lbs.	kg.	lbs.
	75,008	34 024	32,004	14 517	43,004	19 507
Aluminum fenders with ground control outriggers	-268	-121	-99	-45	-169	-76
Tow shackles – front and rear	56	25	32	15	24	10
Carrier aluminum storage box	57	26	16	7	41	19
Detroit Diesel Series 50 engine S/A with Jake brake	50	23	51	23	-1	-0.5
Detroit Diesel Series 60 engine S/A with Jake brake	459	208	514	233	-55	-25
Engine block heater – propane	83	38	105	48	-22	-10
Ether injection	6	3	6	3	0	0
Tire and steel disc wheels (445/65R22.5 fronts – 12R22.5 rears)	255	116	126	57	129	59
Tire and steel aluminum wheels (425/65R22.5 fronts – 12R22.5 rears)	-425	-193	-222	-101	-203	-92
Air conditioning – Carrier cab	124	56	158	71	-34	-15
Pintle hook	25	11	-10	-5	35	16
Electrical and air electrical hook-ups for dolly or trailer	7	3	0	0	7	3
Driver in carrier cab	200	91	252	114	-52	-23
Cab heater assembly w/fuel (diesel)	49	22	9	4	40	18
Cab heater assembly (hydraulic)	129	59	2	1	127	57
Cab air conditioning	264	120	1	0.5	263	119
Counterweight removal system	176	79	-86	-39	262	118
One slab of counterweight on upper	3,000	1 361	-1,572	-713	4,572	2 074
Two slabs of counterweight on upper	6,000	2 722	-3,143	-1 425	9,143	4 147
Rear winch roller	93	42	-44	-20	137	62
Winch with two speeds and 600' (182.88 m) of wire rope	712	323	-197	-89	909	412
Front winch roller	93	42	-31	-14	124	56
Remove 600' (182.88 m) of rope from rear winch	-660	-299	279	127	-939	-426
Remove 600' (182.88 m) of rope from front winch	-660	-299	185	84	-845	-383
Boom float kit	56	25	14	6	42	19
Add fly brackets to boom base section fly options	160	73	141	64	19	9
Add 34' (10.36 m) offsettable fly w/ATB weight (stowed)	1,478	670	1,456	660	22	10
Add 34' – 56' (10.36 – 17.07 m) offsettable fly w/ATB weight (stowed)	2,134	968	1,857	842	277	126
Add floodlight to front of boom base section	10	5	16	7	-6	-2
Add 40-ton (36.43 mt) hookblock stowed behind bumper (4-sheaves)	720	327	1,201	545	-481	-218
Add 50-ton (45.36 mt) hookblock stowed behind bumper (5-sheaves)	1,109	503	1,850	839	-741	-336
Add hookball to front bumper	360	163	600	272	-240	-109
Add auxiliary arm w/ATB switch to boomhead	95	43	200	91	-105	-48
	G.V.W.		Front Axle		Rear Axle	
Transfer one slab of counterweight to carrier deck	74,613	33 844	3,951	1 792	-3,951	-1 792
Transfer two slabs of counterweight to carrier deck	74,613	33 844	7,902	3 584	-7,902	-3 584

¹ Adjust gross vehicle weight & axle loading according to component weight. Note: All weights are ± 3%

Axle	Max. Load @ 65 mph. (105 km/h)
Front	45,400 lbs. (20 593 kg) – aluminum disc wheels with 425/65R22.5 tires
Front	46,400 lbs. (21 047 kg) – steel disc wheels with 445/65R22.5 tires
Rear	50,350 lbs. (22 838 kg.) – aluminum or steel disc wheels

Lifting Capacities

Telescopic Hydraulic Truck Crane

HTC-8650 50-ton (45.36 metric ton)

Boom and fly capacities for this machine are listed by the following sections:

Fully Extended Outriggers

- Working Range Diagram (11,000 lbs. Counterweight)
- 35.5 to 60.3 ft. (10.82 – 18.38 m) main boom capacities, **A-max** mode
- 35.5 to 110 ft. (10.82 – 33.53 m) main boom capacities, Basic Mode “B”
- 34 (10.36 m) ft. offset fly capacities, Basic Mode “B”
- 34 to 56 ft. (10.36 – 33.53 m) two-piece offset fly capacities, Basic mode “B”

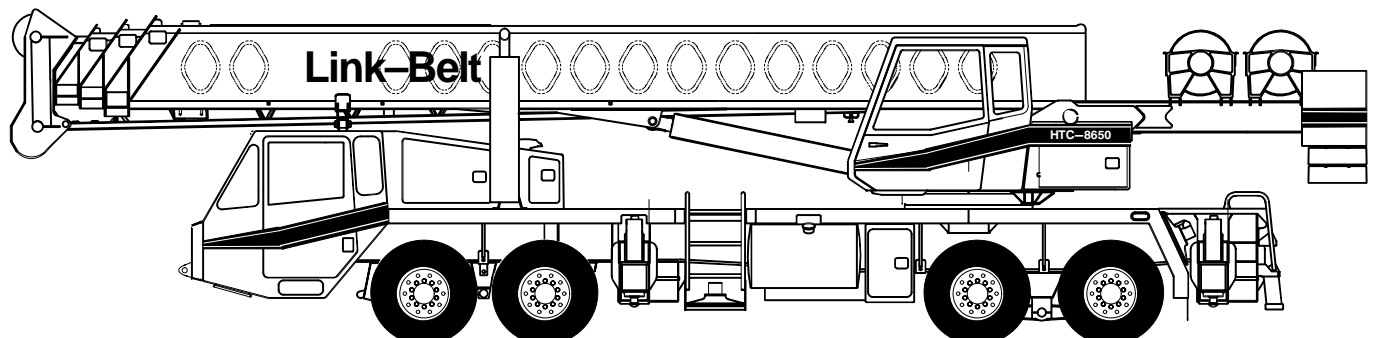

CAUTION: This material is supplied for reference use only. Operator must refer to in-cab Crane Rating Manual to determine allowable machine lifting capacities and operating procedures.



WARNING

READ AND UNDERSTAND THE OPERATOR'S AND SAFETY MANUALS AND THE FOLLOWING INSTRUCTIONS AND RATED LIFTING CAPACITIES BEFORE OPERATING THE CRANE. OPERATION WHICH DOES NOT FOLLOW THESE INSTRUCTIONS MAY RESULT IN AN ACCIDENT.

OPERATING INSTRUCTIONS

GENERAL:

1. Rated lifting capacities in pounds as shown on lift charts pertain to this crane as originally manufactured and normally equipped. Modifications to the crane or use of optional equipment other than that specified can result in a reduction of capacity.
2. Construction equipment can be dangerous if improperly operated or maintained. Operation and maintenance of this crane must be in compliance with the information in the Operator's, Parts, and Safety Manuals supplied with this crane. If these manuals are missing, order replacements through the distributor.
3. The operator and other personnel associated with this crane shall read and fully understand the latest applicable American National Standards ASME B30.5 safety standards for cranes.
4. The rated lifting capacities are based on crane standing level on firm supporting surface.

SET UP:

1. The crane shall be leveled on a firm supporting surface. Depending on the nature of the supporting surface, it may be necessary to have structural supports under the outrigger pontoons or tires to spread the load to a larger bearing surface.
2. When making lifts on outriggers, all tires must be free of supporting surface. All outrigger beams must be extended to the same length; fully retracted, intermediate extended, or fully extended. The front bumper outrigger must be properly extended.
3. When operating on fully retracted outriggers, do not exceed 70° maximum boom angle with 11,000 lb. counterweight. Loss of backward stability will occur causing a backward tipping condition.
4. When making lifts on tires, they must be inflated to the recommended pressure. (See Operation note 20 and Tire Inflation.)
5. Before swinging boom to over side position on tires, or on fully retracted outriggers where capacities are not published, boom sections must be fully retracted and 45° boom angle maintained.
6. For required parts of line, see Wire Rope Capacity and Winch Performance.
7. When installing or removing counterweights, crane must be on fully extended outriggers and boom fully retracted. Do not exceed a 30 ft. radius when moving counterweights.
8. Before setting up on intermediate outriggers, retracted outriggers, or tires, refer to Working Range Diagrams and rated lifting capacities to determine allowable crane configurations.

OPERATION:

1. Rated lifting capacities at rated radius shall not be exceeded. Do not tip the crane to determine allowable loads. For concrete bucket operation, weight of bucket and load shall not exceed 80% of rated lifting capacities. For clamshell bucket operation, weight of bucket and bucket contents is restricted to a maximum weight of 7,000 pounds or 80% of rated lifting capacity, whichever is less. For magnet operation, weight of magnet and load is restricted to a maximum weight of 7,000 pounds or 80% of rated lifting capacity, whichever is less. For clamshell and magnet operation, maximum boom length is restricted to 55 ft. and the boom angle is restricted to a minimum of 35 degrees. Lifts with either fly erected is prohibited for both clam and magnet operation.
2. Rated lifting capacities shown on fully extended outriggers do not exceed 85% of the tipping loads. Rated lifting capacities shown on intermediate extended or fully retracted outriggers are determined by the formula, rated load = (tipping load - 0.1 X load factor)/1.25. Rated lifting capacities shown on tires do not exceed 75% of the tipping loads. Tipping loads are determined by SAE crane stability test code J-765.
3. Rated lifting capacities in the shaded areas above the bold lines, are based on structural strength or hydraulic limitations and have been tested to meet minimum requirements of SAE J-1063 cantilevered boom crane structures— method of test. The rated lifting capacities below the bold lines are based on stability ratings. Some capacities are limited by a maximum obtainable 78° boom angle.
4. Rated lifting capacities include the weight of the hook block, hook ball, slings, bucket, magnet, and auxiliary lifting devices. Their weights must be subtracted from the listed rated capacity to obtain the net load which can be lifted. Rated lifting capacities include the deduct for either fly stowed on the base of the boom. For deducts of either fly erected, but not used, see Capacity Deductions For Auxiliary Load Handling Equipment.
5. Rated lifting capacities are based on freely suspended loads. No attempt shall be made to move a load horizontally on the ground in any direction.
6. Rated lifting capacities are for lift crane service only.
7. Do not operate at radii or boom lengths (minimum or maximum) where capacities are not listed. At these positions, the crane can tip or cause boom failure.
8. The maximum loads which can be telescoped are not definable because of variation in loadings and crane maintenance, but it is permissible to attempt retraction and extension within the limits of the applicable load rating chart.
9. For main boom capacities when either boom length or radius or both are between values listed, proceed as follows:
 - a. For boom lengths not listed, use rating for next longer boom length or next shorter boom length, whichever is smaller.
 - b. For load radii not listed, use rating for next larger radius.

- 10 . The user shall operate at reduced ratings to allow for adverse job conditions, such as: soft or uneven ground, out of level conditions, wind, side loads, pendulum action, jerking or sudden stopping of loads, hazardous conditions, experience of personnel, traveling with loads, electrical wires, etc. Side load on boom or fly is dangerous and shall be avoided.
- 11 . Rated lifting capacities do not account for wind on suspended load or boom. Rated capacities and boom length shall be appropriately reduced as wind velocity approaches or exceeds 20 mph.
- 12 . When making lifts with auxiliary head machinery, the effective length of the boom increases by 2 ft.
- 13 . Power sections of boom must be extended in accordance with boom mode "A" or "B". In boom mode "B" all power sections must be extended or retracted equally.
- 14 . The least stable rated working area depends on the configuration of the crane set up.
- 15 . Rated lifting capacities are based on correct reeving. Deduction must be made for excessive reeving. Any reeving over minimum required (see Wire Rope Capacity) is considered excessive and must be accounted for when making lifts. Use working range diagram to estimate the extra feet of rope then deduct 1 lb. for each extra foot of wire rope before attempting to lift a load.
- 16 . The loaded boom angle combined with the boom length give only an approximation of the operating radius. The boom angle, before loading, should be greater to account for deflection. For main boom capacities, the loaded boom angle is for reference only. For fly capacities, the loaded radius is for reference only.
- 17 . For fly capacities with main boom length less than 110 ft. and greater than 85 ft., the rated capacities are determined by the boom angle using the 110 ft. boom and fly chart. For angles not shown use the next lower boom angle to determine the rated capacity.
- 18 . For fly capacities with main boom length less than 85 ft., the rated capacities are determined by the boom angle only using the 85 ft. boom and fly chart. For angles not shown, use the next lower boom angle to determine the rated capacity.
- 19 . The 35.5 ft. boom length rated lifting capacities are based on boom fully retracted. If the boom is not fully retracted, do not exceed capacities shown for the 45 ft. boom length.
- 20 . Rated lifting capacities on tires depend on tire capacity, condition of tires, and tire air pressure. On tire capacities require lifting from main boom head only on a smooth and level surface. Pick and carry operations are restricted to maximum speed of 1 mph . The boom must be centered over the rear of the crane with two position travel swing lock engaged and the load must be restrained from swinging. For correct tire pressure, see "Tire Inflation".
- 21 . When operating with 6,000 lb. counterweight removed (two, 3,000 lb. counterweights), use the rated capacities for 5,000 lbs. counterweight.

DEFINITIONS:

- 1 . Load Radius: Horizontal distance from a projection of the axis of rotation to the supporting surface before loading to the center of the vertical hoist line or tackle with load applied.
- 2 . Loaded Boom Angle: The angle between the boom base section and horizontal with freely suspended load at the rated radius.
- 3 . Working Area: Area measured in a circular arc about the center line of rotation as shown on the Working Area Diagram.
- 4 . Freely Suspended Load: Load hanging free with no direct external force applied except by the hoist line.
- 5 . Side Load: Horizontal side force applied to the lifted load either on the ground or in the air.
- 6 . No Load Stability Limit: The radius or boom angle beyond which it is not permitted to position the boom because the crane can overturn without any load on the hook.
- 7 . Load Factor: Load applied at the boom tip which gives the same moment effect as the boom mass.

BOOM EXTENSION

Boom Mode "A"
Only inner mid section telescopes

Boom Length (ft.)

35.5
45
55
60.3

Inner Mid Section 298" Stroke Base Section

Boom Mode "B"
Inner mid, outer mid and tip sections telescope simultaneously.

35.5
45
55
65
75
85
95
105
110

Tip Section 298" Stroke Outer Mid Section 298" Stroke Inner Mid Section 298" Stroke Base Section

TIRE INFLATION

Tire Size	Operation	Tire Pressure (psi)
12 R 22.5	1 MPH	120
	Stationary	120
295/80 R 22.5	1 MPH	110
	Stationary	110

PONTOON LOADINGS

Maximum Pontoon Load:	Maximum Pontoon Ground Bearing Pressure:
97,400 lbs.	215 psi

CAPACITY DEDUCTIONS FOR AUXILIARY LOAD HANDLING EQUIPMENT

Load Handling Equipment:	(lbs.)
Auxiliary Head Attached	100
40-ton quick reeve 4 sheave hook block (see hook block for actual weight)	720
60-ton quick reeve 4 sheave hook block (see hook block for actual weight)	1,100
70-ton quick reeve 5 sheave hook block (see hook block for actual weight)	1,400
8.5-ton hook ball (see hook ball for actual weight)	360
Lifting From Main Boom With:	(lbs.)
34 ft. or 56 ft. fly stowed on base (see operation note 4)	0
34 ft. offset fly erected but not used	4,200
56 ft. offset fly erected but not used	7,300
Lifting From 34 ft. Offset Fly With:	
22 ft. fly tip erected but not used	PROHIBITED
22 ft. fly tip stowed on 34 ft. offset fly	PROHIBITED
Note: Capacity deductions are for Link-Belt supplied equipment <u>only</u> .	

WINCH PERFORMANCE

Wire Rope Layer	Winch Line Pulls		Drum Rope Capacity (ft.)	
	Two Speed Winch		Layer	Total
	Low Speed	High Speed		
	Available Lbs.*	Available lbs.		
1	16,407	7,793	110	110
2	15,085	7,165	119	229
3	13,959	6,631	129	358
4	12,990	6,170	138	496
5	12,147	5,770	148	644
6	N/A	N/A	158	802

*Maximum lifting capacity: Type RB Rope = 12,920 Type ZB Rope = 15,600

WIRE ROPE CAPACITY

Maximum Lifting Capacities Based On Wire Rope Strength			
Parts of Line	3/4"		Notes
	Type RB	Type ZB	
1	12,920	15,600	Capacities shown are in pounds and working loads must not exceed the ratings on the capacity charts in the Crane Rating Manual. Study Operator's Manual for wire rope inspection procedures and single part of line applications.
2	25,840	31,200	
3	38,760	46,800	
4	51,680	62,400	
5	64,600	78,000	
6	77,520	93,600	
7	90,440	109,200	
8	103,360	124,800	
9	116,280	140,400	
10	129,200	156,000	
LBCE		DESCRIPTION	
TYPE RB	18 X 19 Rotation Resistant – Compact Strand, High Strength Preformed, Right Regular Lay		
TYPE ZB	36 X 7 Rotation Resistant – Extra Improved Plow Steel – Right Regular Lay		

HYDRAULIC CIRCUIT PRESSURE SETTINGS

Function	Pressure (PSI)
Front And Rear Winch	2,750
Outriggers	3,000
Boom Hoist	2,900
Telescope	3,000
Swing	1,500
Steering	2,000
Bumper Outrigger	650
Pilot Control	500
Counterweight Removal	1,500

WORKING AREAS

HTC on Outriggers
360° Chart

HTC on Tires

Note: These Lines Determine The Limiting Position Of Any Load For Operation Within Working Areas Indicated.

WORKING RANGE DIAGRAM

**Working Range Diagram
On Fully Extended Outriggers**

11,000 lbs. Counterweight

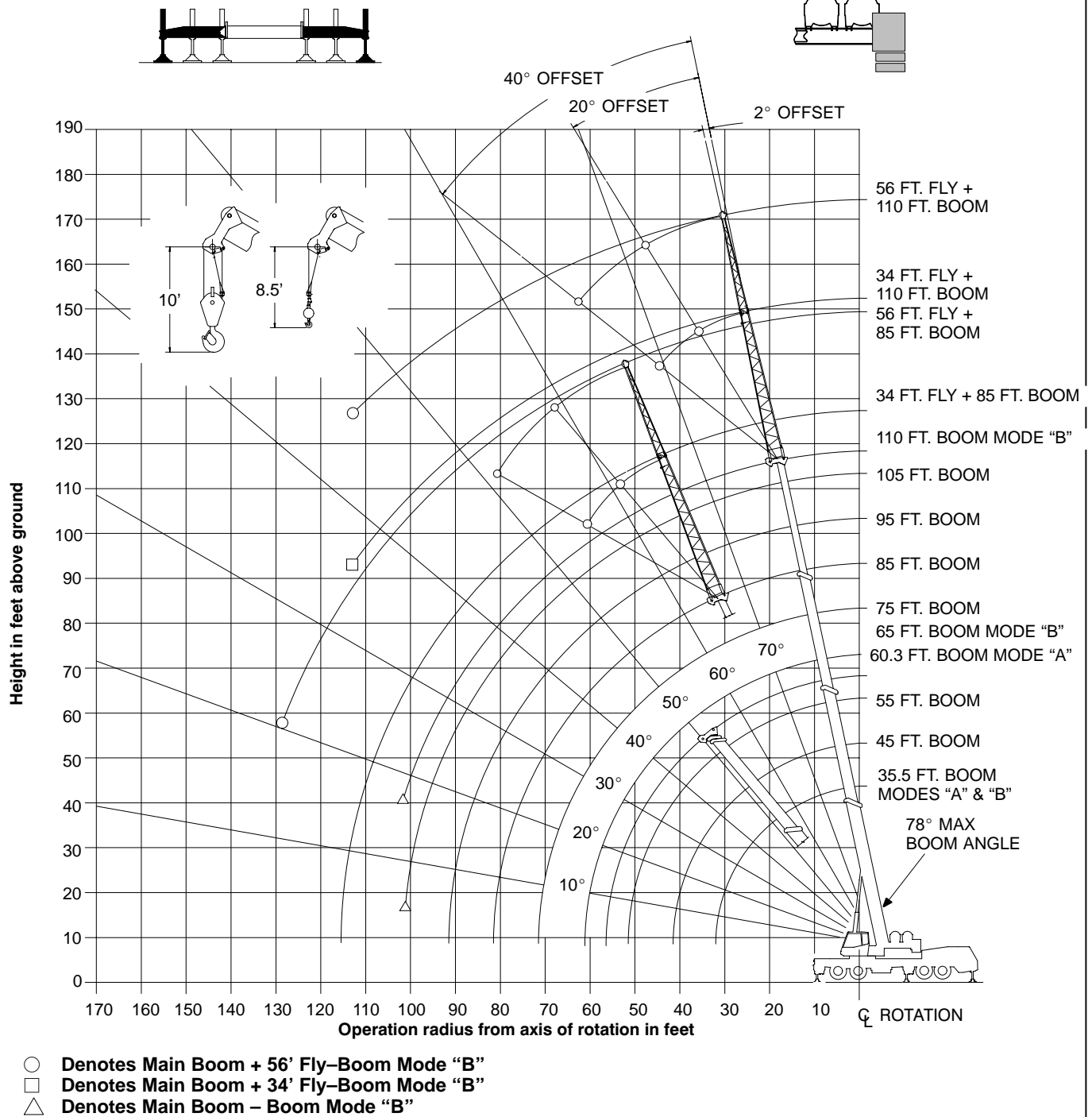

Note: Boom and fly geometry shown are for unloaded condition and crane standing level on firm supporting surface. Boom deflection, subsequent radius, and boom angle change must be accounted for when applying load to hook.

WARNING

Do Not Lower The Boom Below The Minimum Boom Angle For No Load Stability As Shown In The Lift Charts For The Boom Lengths Given. Loss Of Stability Will Occur Causing A Tipping Condition.

Note: Refer To Page 4 For "Capacity Deductions" Caused By Auxiliary Load Handling Equipment.

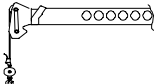

Boom Mode "A"
11,000 lbs. Counterweight

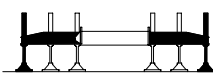

Rated Lifting Capacities In Pounds On Fully Extended Outriggers See Set Up Note 2.

Load Radius (ft)	35.5 Ft.			45 Ft.		
	Loaded Boom Angle (Deg.)	360°	Over Rear	Loaded Boom Angle (Deg.)	360°	Over Rear
10	68.5	100,000	100,000	73.5	87,100	87,100
12	65.0	96,700	96,700	71.0	87,100	87,100
15	59.5	82,500	82,500	66.5	82,100	82,100
20	49.5	64,100	64,100	59.5	63,700	63,700
25	37.5	47,300	49,500	51.5	46,500	49,200
30	20.0	32,800	37,100	42.5	32,500	37,000
35				32.0	24,000	28,000
40				15.5	18,200	21,800
Min. Boom Angle/Cap.	0	19,900	19,900	0	13,200	13,200
Load Radius (ft)	55 Ft.			60.3 Ft.		
	Loaded Boom Angle (Deg.)	360°	Over Rear	Loaded Boom Angle (Deg.)	360°	Over Rear
10	77.0	79,500	79,500	76.5	61,300	61,300
12	75.0	72,200	72,200	73.5	57,600	57,600
15	71.5	63,300	63,300	68.5	47,100	47,100
20	66.0	52,100	52,100	63.0	39,500	39,500
25	60.0	44,000	44,000	57.5	31,800	33,900
30	53.5	32,000	36,500	51.5	23,500	27,500
35	46.5	23,700	27,700	45.0	18,000	21,600
40	38.5	18,100	21,800	37.5	14,000	17,300
45	29.0	14,100	17,300	28.5	11,000	13,900
50	14.5	11,000	13,900	15.0	8,600	11,300
55						
Min. Boom Angle/Cap.	0	8,400	8,400	0	6,500	6,500

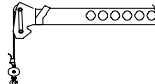

Boom Mode "B"
11,000 lbs. Counterweight

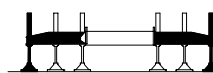

Rated Lifting Capacities In Pounds On Fully Extended Outriggers See Set Up Note 2.

Load Radius (ft)	35.5 Ft.			45 Ft.			55 Ft.		
	Loaded Boom Angle (Deg.)	360°	Over Rear	Loaded Boom Angle (Deg.)	360°	Over Rear	Loaded Boom Angle (Deg.)	360°	Over Rear
10	68.5	100,000	100,000	73.0	42,000	42,000	76.5	42,000	42,000
12	65.0	96,700	96,700	70.5	42,000	42,000	74.5	42,000	42,000
15	59.5	82,500	82,500	66.5	42,000	42,000	71.5	42,000	42,000
20	49.5	64,100	64,100	59.5	42,000	42,000	66.0	42,000	42,000
25	37.5	47,300	49,500	51.5	42,000	42,000	60.0	42,000	42,000
30	20.0	32,800	37,100	42.5	34,000	38,400	53.5	34,600	38,900
35				32.0	25,500	29,300	46.5	26,000	30,000
40				15.5	19,500	23,000	38.5	20,400	23,900
45							29.0	16,200	19,400
50							14.0	13,000	15,900
Min. Boom Angle/Cap.	0	19,900	19,900	0	14,300	14,300	0	10,200	10,200
Load Radius (ft)	65 Ft.			75 Ft.			85 Ft.		
	Loaded Boom Angle (Deg.)	360°	Over Rear	Loaded Boom Angle (Deg.)	360°	Over Rear	Loaded Boom Angle (Deg.)	360°	Over Rear
12	77.0	42,000	42,000	77.0	42,000	42,000			
15	74.5	42,000	42,000	73.0	42,000	42,000	75.5	35,900	35,900
20	70.0	42,000	42,000	69.0	41,700	41,700	72.0	31,500	31,500
25	65.5	42,000	42,000	65.0	35,100	37,100	68.5	28,100	28,100
30	60.0	34,900	39,100	60.5	26,500	30,400	64.5	25,400	25,400
35	54.5	26,300	30,300	56.0	20,900	24,400	61.0	21,100	23,000
40	49.0	20,700	24,200	51.0	16,800	20,000	56.5	17,000	20,200
45	42.5	16,600	19,800	45.5	13,800	16,700	52.5	13,900	16,800
50	35.5	13,600	16,400	40.0	11,500	14,100	48.0	11,600	14,200
55	26.5	11,200	13,700	33.0	9,600	12,000	43.0	9,700	12,200
60	13.0	9,100	11,600	25.0	7,900	10,200	37.5	8,200	10,400
65				12.5	6,600	8,600	31.5	6,900	8,900
70							23.5	5,700	7,700
75							12.0	4,700	6,500
80									
Min. Boom Angle/Cap.	0	7,400	7,400	0	5,400	5,400	0	3,900	3,900
Load Radius (ft)	95 Ft.			105 Ft.			110 Ft.		
	Loaded Boom Angle (Deg.)	360°	Over Rear	Loaded Boom Angle (Deg.)	360°	Over Rear	Loaded Boom Angle (Deg.)	360°	Over Rear
20	77.5	31,800	31,800	76.0	25,700	25,700	77.0	22,600	22,600
25	74.5	28,300	28,300	73.5	23,100	23,100	74.5	22,100	22,100
30	71.0	25,300	25,300	70.5	20,900	20,900	71.5	20,000	20,000
35	68.0	22,800	22,800	67.5	19,000	19,000	69.0	18,300	18,300
40	64.5	20,800	20,800	64.5	17,200	17,400	66.0	16,700	16,700
45	61.0	17,100	19,000	61.5	14,100	15,900	63.0	14,100	15,200
50	57.5	14,000	16,900	58.0	11,900	14,400	60.0	11,900	13,900
55	53.5	11,800	14,300	54.5	10,000	12,400	57.0	10,000	12,400
60	49.5	9,900	12,300	51.0	8,400	10,700	53.5	8,400	10,700
65	45.5	8,300	10,600	47.5	7,100	9,200	50.0	7,100	9,200
70	41.0	7,000	9,100	43.5	6,000	8,000	46.5	6,100	8,000
75	35.5	5,900	7,900	39.0	5,100	6,900	42.5	5,100	7,000
80	30.0	4,900	6,800	34.0	4,300	6,000	38.0	4,300	6,000
85	22.5	4,100	5,800	28.5	3,500	5,100	33.5	3,600	5,200
90	11.5	3,300	4,900	21.5	2,900	4,400	28.0	2,900	4,500
95				11.0	2,300	3,700	21.5	2,300	3,800
100									
Min. Boom Angle/Cap.	0	2,700	2,700	4.5			17.0		

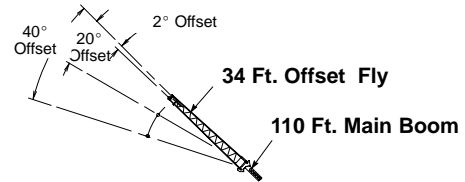
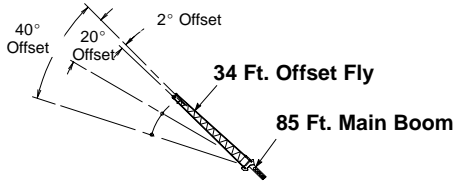

Boom Mode "B"
11,000 lbs. Counterweight

Rated Lifting Capacities In Pounds On Fully Extended Outriggers See Set Up Note 2.

Load Radius (ft)	2° Offset		20° Offset		40° Offset	
	Loaded Boom Angle (Deg.)	360°	Loaded Boom Angle (Deg.)	360°	Loaded Boom Angle (Deg.)	360°
25	77.5	18,600				
30	75.0	17,000				
35	73.0	15,600	77.5	11,000		
40	70.5	14,500	75.0	10,500		
45	68.0	13,600	72.5	10,100	77.0	8,200
50	65.0	12,700	70.0	9,600	74.5	7,900
55	62.5	11,900	67.5	9,300	71.5	7,600
60	60.0	11,100	64.5	8,900	69.0	7,400
65	57.0	9,600	62.0	8,600	66.0	7,200
70	54.0	8,300	59.0	8,200	62.5	7,000
75	50.5	7,200	55.5	7,800	59.5	6,800
80	47.0	6,200	52.5	6,800	56.0	6,700
85	43.5	5,400	48.5	5,900	52.0	6,300
90	40.0	4,700	45.0	5,100	48.0	5,600
95	35.5	4,000	40.5	4,400	43.0	4,600
100	31.0	3,400	35.5	3,700		
105	26.0	2,900	30.0	3,100		
110	19.0	2,400	23.0	2,600		
Min.Bm. Ang./Cap.	0	1,700	0	1,800	0	1,900

Boom Mode "B"
11,000 lbs. Counterweight

Rated Lifting Capacities In Pounds On Fully Extended Outriggers See Set Up Note 2.

Load Radius (ft)	2° Offset		20° Offset		40° Offset	
	Loaded Boom Angle (Deg.)	360°	Loaded Boom Angle (Deg.)	360°	Loaded Boom Angle (Deg.)	360°
35	76.5	10,500				
40	74.5	10,500				
45	72.5	10,500	77.0	9,500		
50	70.5	9,800	75.0	8,700		
55	68.5	8,900	72.5	8,000	76.5	7,400
60	66.5	8,200	70.5	7,400	74.0	6,900
65	64.0	7,500	68.5	6,800	72.0	6,400
70	62.0	6,900	66.0	6,400	69.5	6,000
75	59.5	6,400	63.5	6,000	67.0	5,600
80	57.0	5,900	61.5	5,600	64.5	5,300
85	54.5	5,100	59.0	5,200	62.0	5,000
90	52.0	4,400	56.5	4,900	59.5	4,700
95	49.0	3,700	53.5	4,200	56.5	4,500
100	46.5	3,200	50.5	3,600	53.5	3,900
105	43.5	2,600	47.5	3,000	50.0	3,300
110	40.0	2,200	44.0	2,500	46.5	2,800
115			40.5	2,100	42.5	2,200
120			37.0	1,700		

WARNING

Do Not Lower 34 Ft. Offset Fly In Working Position Below 36° Main Boom Angle Unless Main Boom Length Is 88 Ft. Or Less, Since Loss Of Stability Will Occur Causing A Tipping Condition.

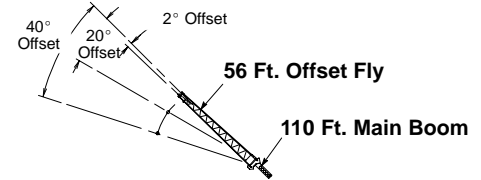
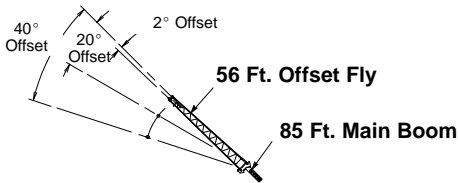

Boom Mode "B"
11,000 lbs. Counterweight

Rated Lifting Capacities In Pounds On Fully Extended Outriggers See Set Up Note 2.

Load Radius (ft)	2° Offset		20° Offset		40° Offset	
	Loaded Boom Angle (Deg.)	360°	Loaded Boom Angle (Deg.)	360°	Loaded Boom Angle (Deg.)	360°
35	76.5	11,100				
40	74.5	10,500				
45	72.5	9,600				
50	70.0	8,800	77.0	6,200		
55	68.0	8,100	75.0	5,900		
60	66.0	7,600	73.0	5,600		
65	63.5	7,000	70.5	5,300	77.0	4,200
70	61.5	6,600	68.5	5,000	74.5	4,000
75	59.0	6,200	66.0	4,800	72.0	3,900
80	56.5	5,800	63.5	4,600	69.5	3,800
85	54.0	5,500	61.0	4,400	66.5	3,700
90	51.5	5,200	58.5	4,200	64.0	3,600
95	48.5	4,600	55.5	4,000	61.0	3,500
100	45.5	4,000	52.5	3,900	57.5	3,500
105	42.5	3,500	49.5	3,800	54.5	3,400
110	39.0	3,000	46.0	3,500	50.5	3,400
115	35.5	2,600	42.5	3,100	46.5	3,300
120	31.5	2,200	38.0	2,600	41.0	2,800
125	27.5	1,900	33.5	2,200		
130	22.0	1,600	27.5	1,800		

Boom Mode "B"
11,000 lbs. Counterweight

Rated Lifting Capacities In Pounds On Fully Extended Outriggers See Set Up Note 2.

Load Radius (ft)	2° Offset		20° Offset		40° Offset	
	Loaded Boom Angle (Deg.)	360°	Loaded Boom Angle (Deg.)	360°	Loaded Boom Angle (Deg.)	360°
40	77.0	6,900				
45	75.5	6,900				
50	74.0	6,900				
55	72.5	6,900				
60	70.5	6,400	77.0	5,600		
65	69.0	5,900	75.0	5,200		
70	67.0	5,400	73.0	4,800		
75	65.0	5,000	71.5	4,500	76.5	4,000
80	63.0	4,600	69.5	4,200	74.5	3,800
85	61.0	4,300	67.5	3,900	72.5	3,600
90	59.0	4,000	65.5	3,600	70.5	3,300
95	57.0	3,700	63.0	3,400	68.0	3,100
100	55.0	3,500	61.0	3,200	66.0	3,000
105	53.0	3,100	59.0	3,000	63.5	2,800
110	50.5	2,600	56.5	2,800	61.0	2,600
115	48.0	2,200	54.0	2,700	58.5	2,500
120			51.5	2,400	55.5	2,400
125			48.5	2,000	52.5	2,300
130					49.5	1,900

WARNING

Do Not Lower 56 Ft. Offset Fly In Working Position Below 20.5° Main Boom Angle Unless Main Boom Length Is 80 Ft. Or Less, Since Loss Of Stability Will Occur Causing A Tipping Condition.

WARNING

Do Not Lower 56 Ft. Offset Fly In Working Position Below 45.5° Main Boom Angle Unless Main Boom Length Is 80 Ft. Or Less, Since Loss Of Stability Will Occur Causing A Tipping Condition.

