

LS-138H II

LATTICE BOOM
CRAWLER CRANE
80-Ton (77.62 mt)

- 80-ton at a 12-foot radius
- 200 feet of conventional boom or 180 feet plus 60 foot boom plus jib combination
- Greater capacities than the competition
- New counterweight removal system with remote control to improve self-assembly
- Lightweight modules for ease of transportation
- New compact travel drives to improve clearance and serviceability
- New two-piece 50,500 lbs. counterweight combination
- New pin-on boom hoist bail
- New improved jib with greater capacities (common to LS-218H)
- New wider and longer lower (side frames hydraulically retract to 11 feet 11 inches for transport)



Link-Belt

The image shows a Link-Belt LS-138H II crawler crane. It is a large, white lattice boom crawler crane with a red counterweight. The crane is mounted on a crawler track system. The background is a blurred construction site with a large concrete structure being worked on.

Link-Belt
CONSTRUCTION EQUIPMENT

Specifications

Hydraulic Lattice Boom Crawler Crane

LS-138H II

80-Ton (72.5 metric ton)

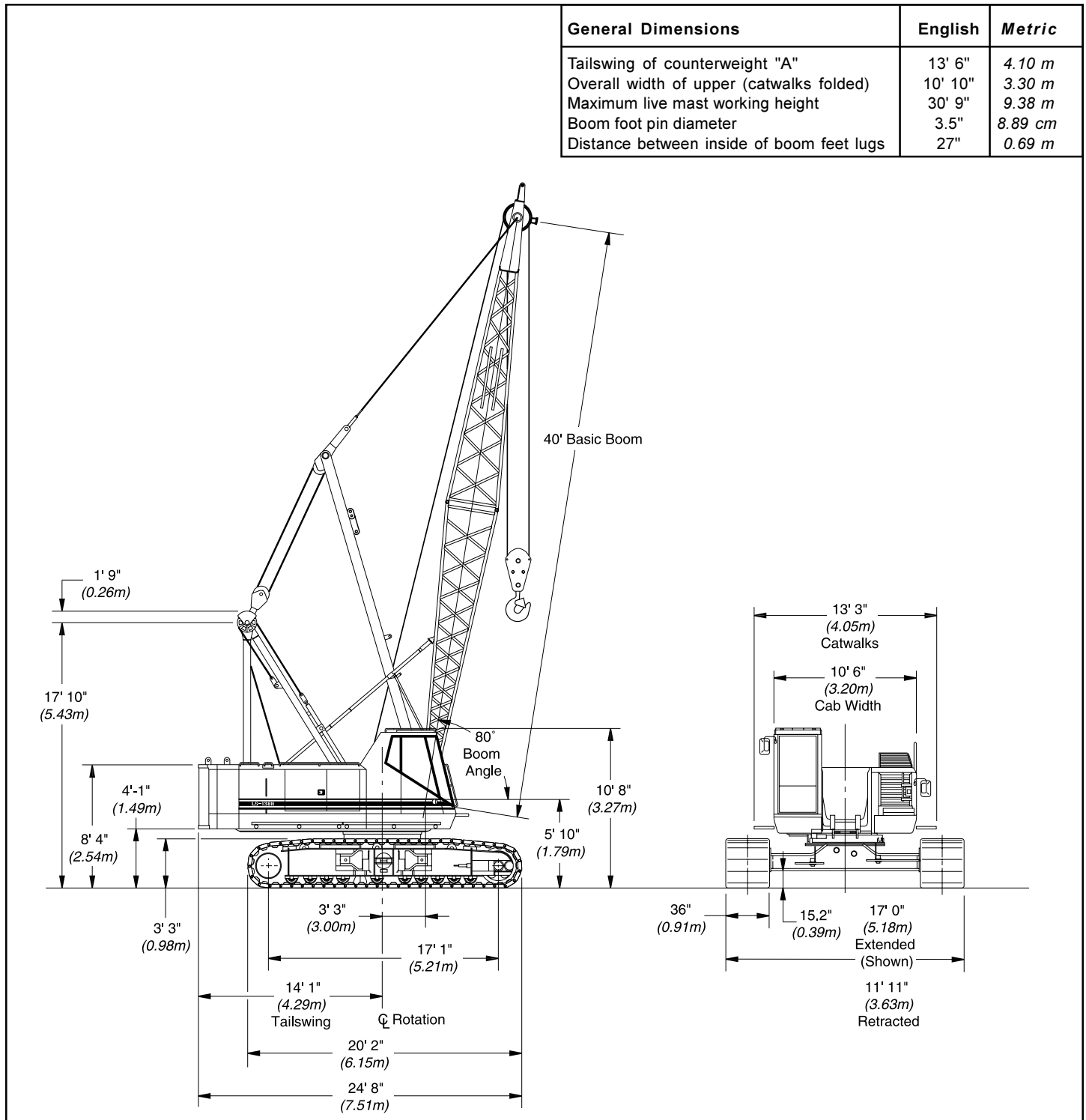

LS-138H II Machine Transport Weights - approximate

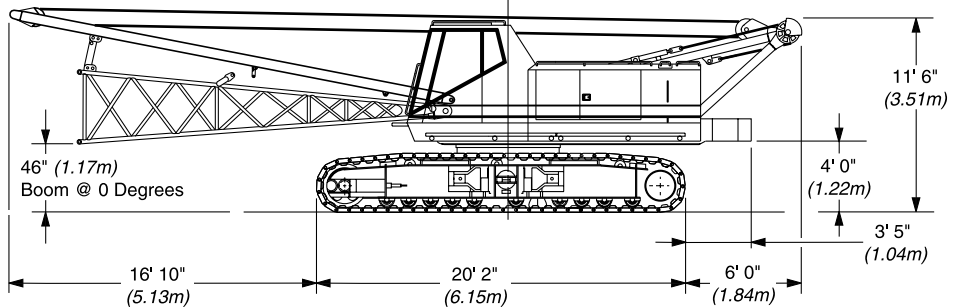
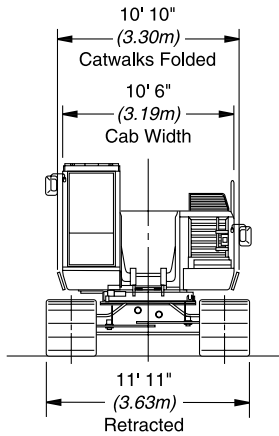

Transport Weight

Rope on both drums, Backstops, Catwalks, and 1/3 tank of fuel
 Tube: 89,751 lbs. (40 710 kg)
 Angle: 90,651 lbs. (41 119 kg)

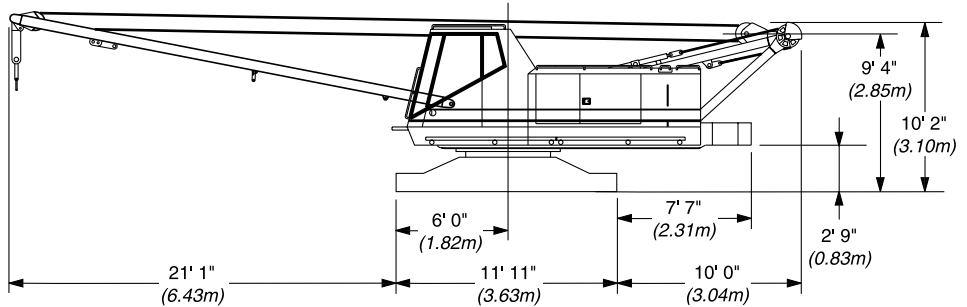
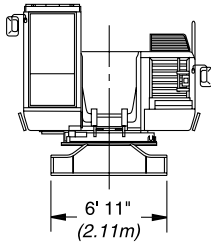

Upper & Carbody Shipping Weight

Rope on both drums, Backstops, Catwalks, and full of fuel
 48,925 lbs. (22 192 kg)

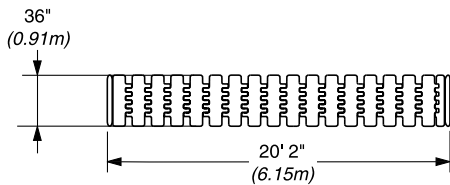

Tread Members w/36" Shoes
19,700 lbs. (8 936 kg)

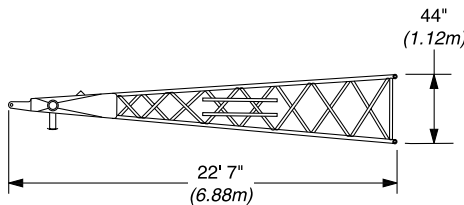

20' (6.10m) Top Section
2,850 lbs. (1 293 kg) Tube Boom
3,500 lbs. (1 588 kg) Angle Boom

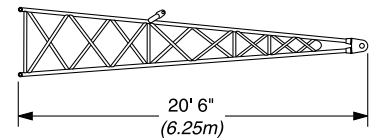

20' (6.10m) Base Section
1,720 lbs. (780 kg) Tube Boom
2,445 lbs. (1 109 kg) Angle Boom

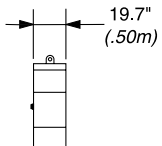

"A" Upper Counterweight
25,250 lbs. (11 453 kg)

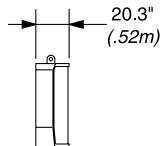

"B" Upper Counterweight
25,250 lbs. (11 453 kg)

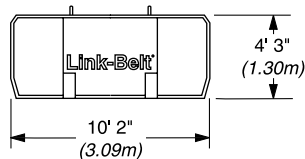

Front Mount Third Drum
1,850 lbs. (839 kg) - w/o Rope

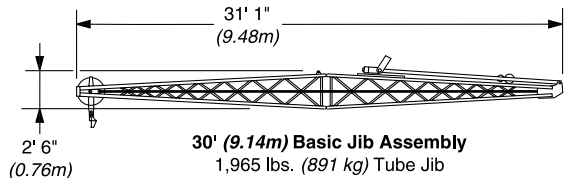

30' (9.14m) Basic Jib Assembly
1,965 lbs. (891 kg) Tube Jib

LS-138H II Transportation Weights

Base machine: Rigid Boom Backstops, 27 Gallons of Fuel, Catwalks (front, right, & left side) 20' Tube Base Section, 24' Live Mast, Bridle & Spreader Bar, 14-Part Boom Hoist Reeving, 700' of Type 'DB' Front Hoist Rope, and 540' of Type 'RB' Rear Hoist Rope.

Item Description	Gross Weight		Transport Loads				Notes and Load Summary
	lbs.	kg.	Load #1	Load #2	Load #3	Load #4	
Base Machine	89,751	40710	1				Numbers in the load columns to the left represent quantities Estimated transport load assume the load out consist of 200' (60.96 m) of tube boom + 60' (18.29 m) of jib with full counterweight. Support loads were targeted at 45,000 lbs. (20412 kg), 8' - 6" (2.59 m) wide, 48' (14.63 m) long, and 13' - 6" (4.11 m) high using a drop deck trailer. This may vary depending on state laws, empty truck/trailer weights and style of trailer. Estimated weights vary by +/- 2% Estimated Total Load of #1 89,751 lbs. (40710 kg.) Estimated Total Load of #2 35,039 lbs. (15893 kg.) Estimated Total Load of #3 32,056 lbs. (14540 kg.) Estimated Total Load of #4 0 lbs. (0 kg.)
Add 'A' Counterweight	25,250	11453			1		
Add 'B' Counterweight	25,250	11453		1			
Add Hydraulic Third Drum w/o rope	1,850	839					
Add 20' Tube Top Section	2,726	1237		1			
Add 10' Tubular Extension w/pins & pendants	669	304			1		
Add 20' Tubular Extension w/pins & pendants	1,065	483		1	2		
Add 30' Tubular Extension w/pins & pendants	1,461	663		2	1		
Add 20' Angle Base Section at 0 degrees	2,618	1188					
Add 20' Angle Top Section with 4 Lifting Sheaves	3,500	1588					
Add 20' Angle Top Section with 3 Lifting Sheaves	3,400	1542					
Add 20' Angle Top Section with 2 Lifting Sheaves	3,300	1497					
Add 10' Angular Extension w/pins & pendants	1,040	472					
Add 20' Angular Extension w/pins & pendants	1,680	762					
Add 30' Angular Extension w/pins & pendants	2,400	1089					
Add Bridle & Spreader Bar Only (No Live Mast)	990	449					
Add Tagline Winder	760	345					
Add Fairlead	500	227					
Add PAT DS-350	100	45					
Add 30' Tubular Jib	1,965	891			1		
Add 15' Tubular Jib Extension	290	132			2		
Add 5' Auxiliary Tip Extension	800	363					
Add Holding Rope - 0.88" x 220' Type 'DB'	312	142					
Add Closing Rope - 0.88" x 165' Type 'DB'	234	106					
Add Inhaul Rope - 0.88" x 80' Type 'M'	108	49					
Add Hoist Rope - 0.88" x 165' Type 'DB'	234	106					
Add Jib Wire Rope 0.88" x 700' Type 'DB'	994	451					
Add 3rd Drum Wire Rope 0.63" x 385' Type 'ZB'	312	142					
Add 3rd Drum Wire Rope 0.63" x 385' Type 'WB'	296	134					
Add Auxiliary Lifting Bail	200	91					
Add 15-Ton Hook Ball - Non Swivel	750	340		1			
Add 15-Ton Hook Ball Swivel	760	345					
Add 80-Ton 4 Sheave Hook Block	2,325	1055		1			
Remove 20' Tube Base Section	-1,988	-902					
Remove Front Hoist Rope 0.88"x700' Type 'DB'	-994	-451					
Remove Jib Wire Rope 0.88" x 540' Type 'RB'	-810	-367					
Remove 24' Live Mast with Bridle & Spreader Bar	-2,618	-1188					
Add 50 Gallons of Fuel	362	164					

Machine Working Weight

Option	Description	Gross Weight Lbs. (kg)	Ground Bearing Pressure PSI (kg/cm ²)
1	Base Machine equipped with 40' (12.20 m) of tubular boom, live mast, "A" counterweight, 700' (213.36 m) front hoist rope, 540' (164.59 m) rear hoist rope, 80-Ton (72.6 mt) Hook Block, 77Gallons (291.4 L) of fuel, and 200 lbs. (90.7 kg) operator.	121,097 (54929)	7.71 (0.54)
2	Option #1 plus "B" counterweight, midpoint pendants, and 160' (48.77 m) of boom extensions to obtain 200' (60.96 m) of main boom.	155,627 (70591)	9.92 (0.70)
3	Option #2 plus 60' (18.29 m) of jib and 15-ton (13.61 mt) hookball – subtract 20' of boom extension and midpoint pendants to obtain maximum 180' + 60' (54.86 m + 18.29 m) of main boom + jib.	157,452 (71419)	10.03 (0.70)
4	Base Machine equipped with 40' (12.20 m) of angle boom, live mast, "A" counterweight, 700' (198.12 m) front hoist rope, 540' (164.59 m) rear hoist rope, 80-Ton (72.57 mt) Hook Block, 77 Gallons (291.4 L) of fuel, and 200 lbs. (90.7 kg) operator.	121,722 (55212)	7.76 (0.54)
5	Option #4 plus "B" counterweight, and 110' (33.53 m) of boom extensions to obtain 150' (45.72 m) of main boom.	156,172 (70838)	9.95 (0.71)
6	Option #5 plus 60' (18.29 m) of jib and 15-ton (13.61 mt) hookball to obtain maximum 150' + 60' (45.72 m + 18.29 m) of main boom + jib.	155,387 (70,482)	9.90 (0.70)

Notes:

- Ground bearing pressure is based on the total weight distributed evenly over the track contact area.
- Total contact area for 36" (0.91 m) track shoes is 15,689 in² (101,219 cm²)

Attachment Options

■ 40'-200' Tubular Boom (12.19 - 60.96 m)

Basic Boom – 40' (12.19m) two-piece design that utilizes a 20' (6.10 m) base section and a 20' (6.10 m) open throat top section with in-line connecting pins on 54" (1.37 m) wide and 44" (1.12 m) deep centers.

- Boom feet on 50" (1.27 m) centers.
- 3" (76.2 mm) diameter chords.
- Lugs on Base Section to attach carrying links.
- Skywalk platform.
- Deflector roller on top section.
- Permanent skid pads mounted on top section to protect head machinery.
- Rigid Sheave guards.
- Five 18" (0.46 m) root diameter steel sheaves mounted on sealed anti-friction bearings.
- Mechanical boom angle indicator.

Optional – Handling system that mounts in the boom base to allow loading/unloading of a counterweight or a boom section onto transport trailers.

Boom Extensions – The following table provides the lengths available and the suggested quantity to obtain maximum boom in 10' (3.05 m) increments. Midpoints pendant connections are required at 80' (24.38 m) for 190' (57.91 m) and 200' (60.96 m) of boom lengths.

Tube Boom Extensions	Suggested Quantity for Max.Boom
10' (3.05 m)	1
20' (6.10 m)	3
30' (9.14 m)	3

- Deflector roller on top of each section.
- Appropriate length pendants.
- Maximum tube boom tip height of 204' (62.18 m)

■ 40'-150' Angle Boom (12.19 - 45.72 m)

Basic Angle Boom – 40' (12.19m) two-piece design that utilizes a 20' (6.10 m) base section and a 20' (6.10 m) open throat top section with in-line connecting pins. Boom extension are 48" (1.22 m) wide and 48" (1.22 m) deep at outside dimensions of angles.

- Boom feet on 50" (1.27 m) centers.
- 4" x 4" x 0.38" (101.6 x 101.6 x 9.53 mm) angular chords

- Lugs on Base Section to attach carrying links
- Skywalk platform
- Deflector roller on top section
- Permanent skid pads mounted on top section to protect head machinery
- Rigid Sheave guards
- Four 18" (0.46 m) root diameter steel sheaves mounted on sealed anti-friction bearings
- Mechanical boom angle indicator

Optional – Handling system that mounts in the boom base to allow loading/unloading of a counterweight or a boom section onto transport trailers. Three-sheave head machinery for clam applications or two wide mouth sheaves for dragline applications.

Angle Boom Extensions – The following table provides the lengths available and the suggested quantity to obtain maximum boom in 10' (3.05 m) increments. Midpoints pendant connections are not required.

Angle Boom Extensions	Suggested Quantity for Max. Boom
10' (3.05 m)	1
20' (6.10 m)	2
30' (9.14 m)	2

- Deflector roller on top of each section
- Appropriate length pendants
- Maximum angle boom tip height of 154' (46.94 m)

■ 30' - 60' Tubular Jib (9.14 – 18.29 m)

Basic Jib – 30' (9.14 m) two-piece design that utilizes a 15' (4.57 m) base section and a 15' (4.57 m) top section with in-line connecting pins on 32" (0.81 m) wide and 24" (0.61 m) deep centers.

- 2" (50.8 mm) diameter tubular chords
- One 18.5" (0.47 m) root diameter steel sheave mounted on a sealed anti friction bearings
- 15' jib extension provides jib lengths at 45' (13.76 m) and 60' (18.29 m)
- Jib offset angles at 5, 15 and 25 degrees
- Maximum tip height of boom + jib is 242' (73.76 m)

■ Auxiliary 5' (1.52 m) Tip Extension

Designed to use instead of a jib to provide clearance between working hoist lines. The extension is equipped with a single 15.25" (0.39 m) root diameter steel sheave mounted on a sealed anti-friction bearing. Maximum capacity is 9-ton (8.16 mt).

■ Boom Hoist System

Designed to lift-off maximum boom or maximum boom plus jib unassisted, operates up to a maximum boom angle of 82 degrees. Automatically limits maximum boom angle operation.

- Hydraulic controlled retractable gantry frame
- Pin-on bail frame
- 14-part reeving with 5/8" (14.7 mm) type 'AC' wire rope
- Bridle assembly
- 24' (7.31 m) live mast (optional for angle attachment)
- Two 1.25" (31.75 mm) pendants.
- Tubular boom backstops (rigid type)
- Sheaves contain sealed anti-friction bearings
- Boom speed from 10° - 70° is 52 seconds with no load and 94 seconds with full load. Speed was determined using 100 ft. of tube boom

Revolving Upperstructure

■ Frame

All welded steel frame with precision-machined surfaces for mating parts.

■ Engine

Isuzu A-6SDITQB with oil filter, oil cooler, air cleaner, fuel filter, water separator, hour meter, tachometer and electrical shutdown.	
Number of cylinders	6
Bore and stroke – inch — (mm)	4.72 X 5.71 (120 X 145)
Piston displacement — (cm ³)	600 (in ³) (9839)
Engine rpm at full load speed	2,100
Hi-idle rpm	2,325
Horsepower at full load speed	207 (155 kw)
Peak torque - ft. / lbs. — (joule)	513 ft. / lbs. 696
Peak torque - rpm	1,400
Electrical system	24 volt
Batteries	2 - 12 volt

■ Specifications Hydraulic System

Hydraulic Pumps – The pump arrangement is designed to provide hydraulically powered functions allowing positive control, with independent or simultaneous operation of all crane functions.

- Two variable displacement pumps operating at 4,000 psi (281.24 kg/cm²) and 64 gallons/min. (243 l/min) powers both hoist drums, boom hoist drum, optional third drum, and travel.
- One fixed displacement gear type pump operating at 3,600 psi (250 kg/cm²) and 32 gallons/min. (121 l/min) powers the swing and treadmember retract cylinder.
- One fixed displacement gear type pump operating at 1,250 psi (85 kg/cm²) and 8 gallons/min. (32 l/min) powers the pilot control system, clutches, brakes, pump controls, counterweight removal system, and optional handling system mounted in boom base.

Pump Control (“Fine Inching”) mode – Special pump setting, selectable from operator’s cab, that allows very slow movements of hoist drums, boom hoist drum, and travel for precision work.

Hydraulic Reservoir – 78 US gallons (295 L), equipped with sight level gauge. Diffusers built in for deaeration.

Filtration – One 10 micron, full flow, line filter in the control circuit. All oil is filtered prior to entering the reservoir.

Counterbalance Valves – All hoist motors are equipped with counterbalance valves to provide positive load lowering and prevent accidental load drop if the hydraulic pressure was suddenly lost.

■ Load Hoist Drums

Each drum contains a pilot controlled bi-directional axial piston motor and a planetary gear reduction unit to provide positive control under all load conditions.

- Power up/down & freefall operation modes.
- Automatic brake mode (spring applied hydraulic released band type brake).
- 7/8” (22.22 mm) grooved laggings.
- Drum pawl controlled manually.
- Electronic drum rotation indicators.
- Mounted on anti-friction bearings.
- 17.64” (0.45 m) root diameter.
- 29.92” (0.76 m) outside flange diameter.
- 19.84” (0.50m) width.

Note: The freefall operational mode is designed to prevent load lowering even if the freefall switch is accidentally activated. The automatic brake mode meets all OSHA requirements for personnel handling.

Drum Clutches – Speed-o-Matic™ power hydraulic two shoe clutch design that uses a 20” (0.51m) diameter x 5” (127 mm) wide shoe that internally expands to provide load control. Swept area is 314 in² (2026 cm²).

■ Optional Third Hoist Drum

The hydraulic winch is pinned to the front of the upper frame and is used in conjunction with a fleeting sheave and 3-sheave idler assembly to run the wire rope over the boom top section.

- Free-spooling capability for pile driving applications
- 10.63” (0.27 m) root diameter
- 20” (0.51 m) outside flange
- 13.5” (0.34 m) width
- Mounted on anti-friction bearings

■ Boom Hoist Drum

Contains a pilot controlled bi-directional axial piston motor and a planetary gear reduction unit to provide positive control under all load conditions.

- Spring applied hydraulic released disc type brake controlled automatically
- 5/8” (15.88 mm) grooved lagging
- Drum pawl controlled automatically.

- Mounted on anti-friction bearings
- 12.60” (0.31 m) root diameter
- 24.41” (0.62 m) flange diameter
- 9.57” (0.24 m) width

■ Swing System

Mechanical linkage controls the bi-directional axial piston motor and a planetary gear reduction unit to provide positive control under all load conditions.

- Spring applied hydraulic released 360 degree multi-plate brake
- Free swing mode when lever is in neutral position
- Two position positive house lock
- Audio/Visual swing alarm
- Maximum swing speed is 2.8 r.p.m.

■ Upper Counterweight

Consist of a two piece design that is easily lowered to the ground using a remote control box to hydraulically retract the gantry and function the two counterweight removal cylinders.

- 25,250lbs. (11453 kg) “A” upper counterweight.
- Optional – 25,250lbs. (11453 kg) “B” upper counterweight can be added to maximize capacities.

■ Operators Cab and Controls

Fully enclosed modular steel compartment is independently mounted and insulated to protect against vibration and noise.

- All tinted/tempered safety glass
- Sliding entry door and front window
- Swing up roof window with wiper
- Door and window locks
- Heater with circulating fan
- Sun visor
- Engine instrumentation panel (tacho meter, voltmeter, engine oil pressure, engine water temperature, fuel level, hydraulic oil temperature, and service monitor system)
- Electronic drum rotation indicators
- Six way adjustable seat with seat belt
- Dry chemical fire extinguisher
- Hand and foot throttle
- Fully adjustable single axis control levers
- Swing lever with swing brake and horn located on handle
- Bubble type level

LS-138H II Load Hoisting Performance

Available line speed and line pull - based on Isuzu A-6SDITQB at 2,100 rpm full load speed. Line Pulls are not based on wire rope strength. See wire rope chart for maximum permissible single part of line working loads.

Rope layer	Front or Rear Drum - 7/8" (22.22 mm) wire rope											
	Maximum Line Pull		No load line speed		Full load line speed		Pitch Diameter		Layer		Total	
	lbs.	kg	ft./min	m/min	ft./min	m/min	in.	mm	ft.	m	ft.	m
1	32430	14710	298	91	113	35	18.5	470	100	30	100	30
2	29630	13440	326	99	124	38	20.3	516	109	33	209	64
3	27274	12372	354	108	135	41	22.0	559	119	36	327	100
4	25266	11461	382	116	145	44	23.8	605	128	39	455	139
5	23533	10674	410	125	156	48	25.5	648	137	42	593	181
6	22023	9989	438	134	167	51	27.3	693	147	45	740	225
7	—	—	—	—	—	—	29.0	737	156	48	896	273

Rope layer	Boom Hoist Drum - 5/8" (15.88 mm) wire rope											
	Maximum Line Pull		No load line speed		Full load line speed		Pitch Diameter		Layer		Total	
	lbs.	kg	ft./min	m/min	ft./min	m/min	in.	mm	ft.	m	ft.	m
1	17,832	8089	196	60	109	33	13.2	336	48	15	48	15
2	16,282	7385	214	65	119	36	14.5	368	52	16	100	31
3	14,979	6794	233	71	130	40	15.7	400	57	17	157	48
4	13,869	6291	251	77	140	43	17.0	432	61	19	218	67
5	12,913	5857	270	82	151	46	18.3	464	66	20	284	87
6	12,080	5479	289	88	161	49	19.5	496	70	21	355	108
7	11,348	5147	307	94	171	52	20.8	528	75	23	430	131
8	10,699	4853	326	99	182	55	22.0	560	80	24	509	155

Rope layer	Third Drum - 5/8" (15.88 mm) wire rope											
	Maximum Line Pull		No load line speed		Full load line speed		Pitch Diameter		Layer		Total	
	lbs.	kg	ft./min	m/min	ft./min	m/min	in.	mm	ft.	m	ft.	m
1	15,041	6822	157	48	143	44	11.25	286	57	17	57	17
2	13,537	6140	175	53	159	48	12.50	318	64	20	121	37
3	12,307	5582	192	59	175	53	13.75	349	71	22	192	59
4	11,282	5117	210	64	191	58	15.00	381	77	23	269	82
5	10,414	4724	228	69	207	63	16.25	413	83	25	352	107
6	9,671	4387	245	75	223	68	17.50	445	90	27	442	135

Wire Rope Application	Diameter		Length		Type	Maximum Permissible Load	
	in.	mm	ft.	m		lbs.	kg
Boom Hoist	5/8	15.88	610	186	AC	11,770	5339
Front Hoist	7/8	22.22	700	213	DB	22,740	10315
Rear Hoist (optional)	7/8	22.22	540	165	RB	17,520	7947
Rear Hoist (optional)	7/8	22.22	700	213	DB	22,740	10315
Third Drum (optional)	5/8	15.88	385	117	ZB	11,080	5026
Third Drum (optional)	5/8	15.88	385	117	WB	13,650	6192

Rope Type	Description
DB	6 x 26 (6 x 19 Class) -Warrington Sale - Extra Improved Plow Steel - Preformed -Right Lay - Regular Lay - I.W.R.C.
RB*	19 x 19 Rotation Resistant - Extra Lay, Improved Plow Steel - Preformed - Right Lay - Regular Lay. Swaged - SF=5.1
ZB	36 x 7 - Non-rotating - Extra Improved Plow Steel - Right Lay - Regular Lay - S.F. = 5.1
WB	8 Strand - Regular Lay
AC	9 Strand - Compacted - Crush Resistant

* - Use of swivel ball is not recommended.

■ Load Indicator / Rated Capacity Limiter

Standard Equipment – PAT EI-65 load indicator provides two linersiders, angle sensor, computer, display, and anti two block equipment to provide the following information.

- Boom length & angle
- Jib length & angle
- Load on hook
- Load radius
- Tip height
- Anti-two block warning & function limiters.
- Operation mode
- Operator settable alarms provide audio/visual warning

Optional Equipment – PAT DS-350 rated capacity limiter provides all the same equipment and features of the standard EI-65 in conjunction with the following features.

- Provides an audio/visual warning when the load on hook is within 90% of the cranes rated load.
- Provides an audio/visual warning and limits functions when the load on hook is at 100% of the cranes rated load.

Note: The DS 350 function limiters are activated for anti-two block and overload conditions. These limiters are designed to prevent hoist up on front and rear drums and boom hoist down.

■ Additional Equipment — Standard

- 57.88" (1.47 m) outside diameter turn table bearing
- Front, Right & Left side removable catwalks
- 77 US Gallons (291.5 L) fuel tank (usable quantity)
- Machine lifting links

■ Additional Equipment — Optional

- Rud-o-matic® model 1248 tagline winder for angle boom (double barrel, spring wound, drum type)
- Rud-o-matic® model 648 tagline winder for tube boom
- Full revolving type Fairlead with barrel, sheaves and guide rollers

Lower Structure

■ Carbody

All welded box construction frame with precision-machined surfaces for turn-table bearing and rotating joint.

- 8'-10.7" (2.71 m) overall width
- 11'-11" (3.63 m) overall length

■ Treadmembers

All welded precision-machined steel frames can be hydraulically extended and retracted by a hydraulic cylinder mounted in the lower frame.

- 14' (4.27 m) extended gauge
- 8'-11" (2.72 m) retracted gauge
- 20'-2" (6.15 m) overall length
- 36" (0.91 m) wide track shoes
- 11 sealed (oil filled) track rollers per treadmember
- Sealed (oil filled) idler and drive sprockets
- Compact travel drives
- Hydraulic self adjusting tracks

Travel and Steering - Each Treadmember contains a pilot controlled bi-directional axial piston motor and a planetary gear reduction unit to provide positive control under all load conditions.

- Individual control provides smooth precise maneuverability including full counter-rotation
- Spring applied hydraulic released disc type brake controlled automatically
- Maximum travel speed is 1.0 mph (1.7 km/h) in high speed & 0.6 mph (1 km/h) in low speed
- Designed to 30% gradeability

THE LS-138H II

ALL THE TRADITIONAL
LINK-BELT STANDARDS:
PRECISION, COMFORT,
RELIABILITY,
CONTROLLABILITY,
PLUS INDUSTRY-FIRST
TECHNOLOGY AND
INNOVATIONS



Service Continues After The Sale

When you have invested in a Link-Belt crane, you have also invested in a 125-year legacy of outstanding customer service and support. Link-Belt helps you maintain your investment with the industry's most comprehensive crane product support. Highly trained parts and service department technicians are committed to responding quickly to your downtime and get you going again ... fast!

KEY FEATURES

Base Rating

- 80-ton nominal rating

Transportability

- Less than 90,000 lbs. with treadmembers, boom base, live mast, and hoist ropes

Boom

- 40 to 200 feet of tubular boom (increased length)
- 44" x 54" cross-section
- Boom configurations in 10-foot increments
- Maximum tip height of 204 feet

Attachments

- 30 to 60 feet of tubular jib (increased capacities)
- 24" x 32" cross-section
- Jib configurations in 15-foot increments
- 5, 15 and 25 degree offsets
- 180 feet + 60 feet provide maximum tip height of 242 feet
- Auxiliary 5-foot tip extension (9-Ton)

Upper Counterweight

- 25,250 lbs. "A" (new)
- 25,250 lbs. "B" (optional) (new)
- Hydraulic counterweight removal system with handheld remote control – lowers CTWT to the ground (new)

Front and Rear Hoist Drums

- Grooved for 7/8 inch wire rope
- Power up/power down and freefall operation modes
- 17.63 inch root diameter drums (new)
- 742 feet of rope storage capacity
- 32,430 lbs. of maximum line pull (new)
- 438 FPM of maximum single line speed (new)
- Drums powered by pilot-operated axial piston motors
- Drum pawls

Boom Hoist System

- 24-foot live mast
- Pin-on boom hoist bail (new)
- 14-part reeving with 5/8 inch type "AC" wire rope
- Hoist drum grooved for 5/8 inch wire rope
- Hoist drum powered by pilot-operated axial piston motor
- Drum pawl

Power Plant

- Isuzu A-6SDITQB diesel engine with 207 brake HP
- Two variable displacement pumps
- Two gear type pumps

Swing System

- Free swing mode
- Pilot-operated axial piston motor
- 360 degree multi-plate disc brake
- Two-position positive house lock
- Audio/visual swing alarm

Rated Capacity Indicator

- PAT EI-65 (standard)
- PAT DS-350 rated capacity limiter (optional)
- Two linersiders standard with basic boom
- Anti-two block with function kick out

Operator's Cab

- Pilot-operated single axis control levers
- Electronic drum rotation indicators
- Fully enclosed steel modular cab with safety glass
- Full engine instrumentation package
- Swing up roof window with wiper
- Heater/defroster with circulating fan

Lower

- 14-foot gauge extended (new)
- 8-foot, 11-inch gauge retracted
- 20-foot, 2-inch overall length (new)
- Compact hydrostatic travel drives (new)
- 36-inch track shoes
- Sealed (oil filled) track rollers, idler and drive sprockets
- Hydraulic track adjustment
- 59,500 lbs. of tractive effort per track (new)

Miscellaneous Standard Equipment

- Blocks for over end blocked capacities (new)
- Mechanical boom angle indicator
- Rigid sheave guards
- 7/8 inch x 700 feet of type "DB" front hoist rope
- Front, left side and right side catwalks
- Machine lifting links
- Lower step assemblies

Miscellaneous Optional Equipment

- Hydraulic front mount third drum (15,000# line pull)
- Angle attachment used for lift crane, clamshell, or dragline work
- Attachment extensions available in 10, 20 and 30-foot lengths
- Midpoint suspension system (new)
- 15-ton headache ball, swivel and non-swivel
- 80-ton hook block
- Counterweight boom auxiliary handling device

Link-Belt Construction Equipment Company
Lexington, Kentucky

© Link-Belt is a registered trademark. Copyright 1999. We are constantly improving our products and therefore reserve the right to change designs and specifications. Litho in U.S.A. 2/99 #4228

Link-Belt
CONSTRUCTION EQUIPMENT

Link-Belt[®]

CONSTRUCTION EQUIPMENT

LS – 138H II

CRANE RATING MANUAL

- 44" x 54" TUBULAR BOOM
- 20' OPEN THROAT PEAK SECTION
- 1.25" DIAMETER PENDANTS
- WITH LIVE MAST
- 14'0" GAUGE
AND 20'2" OVERALL LENGTH

SERIAL NUMBER _____

For Replacement, Order Part Number H7P0002.
(022399)

R Link-Belt is a registered trademark.

Table Of Contents

SPECIFICATIONS

OPERATING INSTRUCTIONS	3
WIRE ROPE CAPACITY	4
WORKING AREAS	5
GENERAL DIMENSIONS	6
LIFTOFF CAPABILITIES	7

LIVE MAST CAPACITIES

LIVE MAST LIFTING CAPACITIES	9
20' BASE SECTION CYLINDER LIFTING CAPACITIES	10
CRANE ASSEMBLY COMPONENT WEIGHTS	11

DUTY CYCLE CAPACITIES

DUTY CYCLE NOTES FOR TUBULAR BOOM	13
DUTY CYCLE CAPACITIES FOR TUBULAR BOOM	14

MAIN BOOM CAPACITIES

WORKING RANGE DIAGRAM (40'-200' OPEN THROAT BOOM)	15
CAPACITY DEDUCTIONS FOR LIFTING OFF MAIN BOOM HOOK WITH JIB INSTALLED	16
MAXIMUM ALLOWABLE CAPACITIES FOR 5 FOOT TIP EXTENSION	17
BOOM CAPACITIES (40'-200' OPEN THROAT BOOM)	18-34

JIB CAPACITIES

TUBULAR JIB NOTES FOR OPEN THROAT BOOM	35-36
WORKING RANGE DIAGRAM (40'-180' OPEN THROAT BOOM WITH 30'-60' JIB)	37
WORKING RANGE DIAGRAM (190' OPEN THROAT BOOM WITH 30' JIB)	38
JIB CAPACITIES (H7P0004 PAGE 1 THRU 50)	



WARNING

READ AND UNDERSTAND THE OPERATOR'S AND SAFETY MANUALS AND THE FOLLOWING INSTRUCTIONS AND CHART VALUES BEFORE OPERATING THE CRANE. OPERATION WHICH DOES NOT FOLLOW THESE INSTRUCTIONS MAY RESULT IN AN ACCIDENT.

OPERATING INSTRUCTIONS

GENERAL:

1. Rated lifting capacities in pounds as shown on lift charts pertain to this crane as originally manufactured and normally equipped. Modifications to the crane or use of optional equipment other than that specified can result in a reduction of capacity.
2. Construction equipment can be dangerous if improperly operated or maintained. Operation and maintenance of this crane must be in compliance with the information in the Operator's, Parts, and Safety Manuals supplied with this crane. If these manuals are missing, order replacements through the distributor.
3. The operator and other personnel associated with this crane shall read and fully understand the latest applicable American National Standards Institute (ANSI) safety standards for cranes.
4. All capacities listed in this book are in compliance with ASME/ANSI B30.5c-1998, SAE J987-April 1994, and SAE J765-October 1990.

LIFT CRANE OPERATION:

1. Capacities shown are in pounds and are not more than 75% of the tipping loads with the crane standing level on firm supporting surface. A deduction must be made from these capacities for weight of hook block, hook ball, sling, grapple, load weighing device, etc. When using main hook while jib is attached, reduce capacities by values shown on Capacity Deductions For Lifting Off Main Boom Hook With Jib Installed. When using main hook while 5ft. tip extension is attached, reduce capacities by values shown on Capacity Deductions For Lifting Off Main Boom Hook With 5ft. Tip Extension Installed. See Operator's Manual for all limitations when raising or lowering attachment.
2. The crane capacities in the shaded areas are based on structural strength. The crane

capacities in the non-shaded areas are based on stability ratings.

3. For recommended reeving, parts of line, wire rope type, and wire rope inspection, see Wire Rope Capacity chart, Operator's Manual, and Parts Manual.
4. Load ratings in this Crane Rating Manual are based on freely suspended loads and make no allowances for such factors as the effect of the wind, ground conditions, and operating speeds. The operator shall therefore reduce load ratings in order to take these conditions into account.
5. Rated lifting capacities do not account for the effects of wind on a suspended load or boom. Lifting capacities should be considered acceptable for wind speeds less than 20 mph and appropriately reduced for wind speeds greater than 20 mph. Extreme caution should be used when lifting heavy loads or loads with large wind sail area under high wind conditions (over 20 mph).
6. The 24ft. live mast must be used for all capacities in this Crane Rating Manual.
7. The least stable rated condition is over the side.
8. Booms must be erected and lowered over the end.
9. Do not operate at radii and boom lengths where the Crane Rating Manual lists no capacity. Do not use longer booms or jibs than those listed in this Crane Rating Manual. Any of the above can cause a tipping condition, or boom and jib failure.
10. These capacities apply only to the crane as originally manufactured and normally equipped by Link-Belt Construction Equipment Company.

FOR OVER END CAPACITIES ONLY

1. These capacities can be lifted over either end with the crane standing level on a firm supporting surface with adequate blocking placed under the tread member sprockets/idlers, to prevent rocking.
2. Do not travel with a load.

WIRE ROPE CAPACITY

Parts of Line	7/8"		5/8"		
	Type "DB"	Type "RB"	Type "ZB"	Type "WB"	Notes
1	22,700	17,520 *	11,000 **	13,650 *	Capacities shown are in pounds and working loads must not exceed the ratings on the capacity charts in this Crane Rating Manual. Study Operator's Manual for wire rope inspection procedures.
2	45,400	35,040	22,000	27,310	
3	68,100	52,560	33,000	40,970	
4	90,800	70,080	44,000	54,620	
5	113,500	87,600	55,000	68,280	
6	136,200	105,120	66,000	81,940	
7	158,900	122,640	77,000	95,600	
8	181,600	140,160	88,000	109,250	
LBCE Type	Description				
DB	6 x 26 (6 x 19 Class) – Warrington Seale – Extra Improved Plow Steel – Preformed – Right Lay – Regular Lay – I.W.R.C.				
RB	19 x 19 Rotation Resistant– Extra Extra Improved Plow Steel – Preformed – Right Lay – Regular Lay. Swaged – SF = 5:1				
ZB	36 x 7 Class – Non–Rotating – Extra Improved Plow Steel – Right Lay – Regular Lay – S.F. = 5:1				
WB	8 Strand – Regular Lay				
* Use of swivel end with 1 part of line is not recommended.					
** Swivel end is recommended for operation with 1 part of line.					

WORKING AREAS

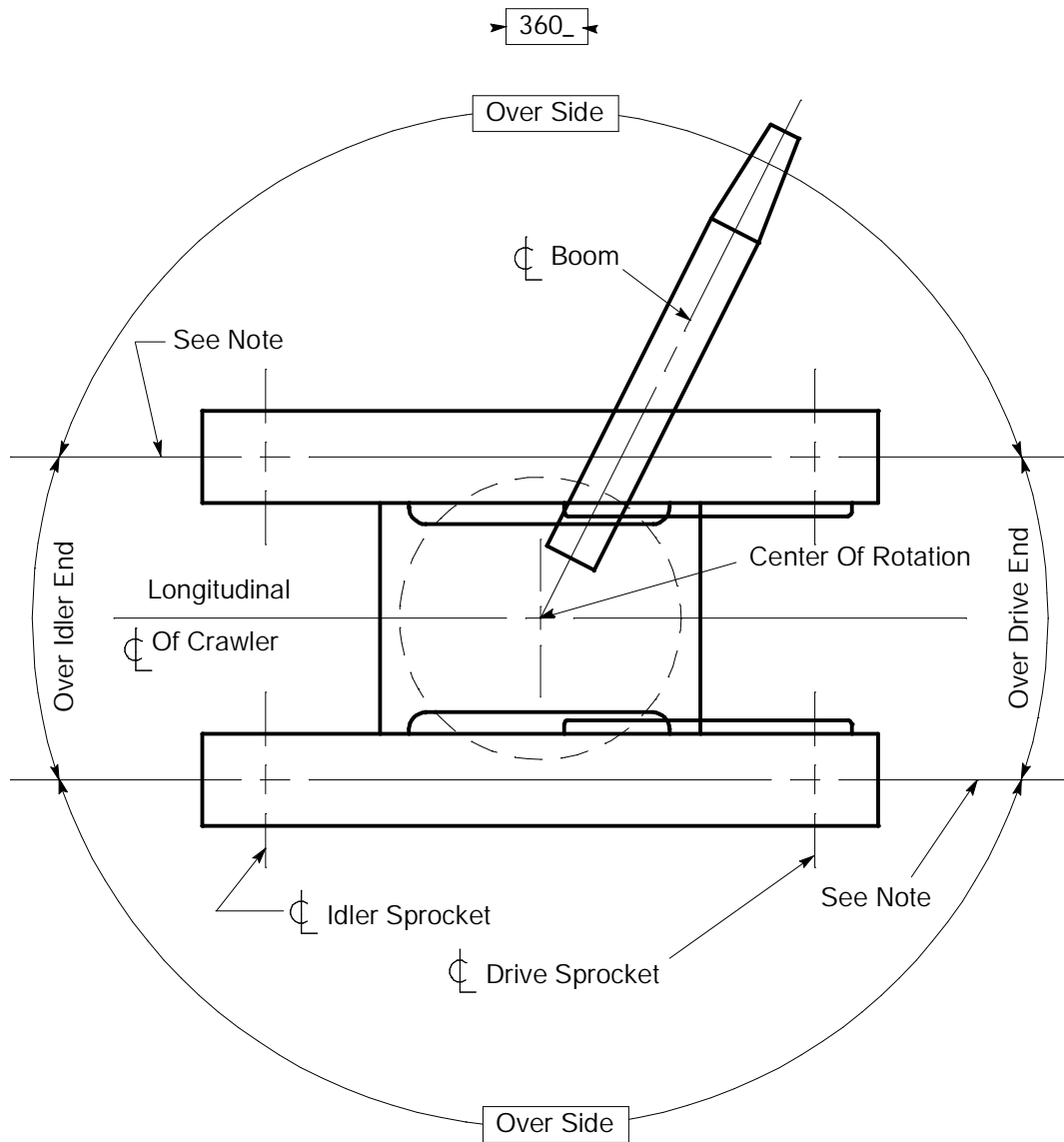

Note:

1. These Lines Determine The Limiting Position Of Any Load For Operation Within Working Areas Indicated.

GENERAL DIMENSIONS

GENERAL DESCRIPTION		DIMENSION
A	TREADMEMBER HEIGHT	38.5"
B	GROUND CLEARANCE-CTWT	49"
C	OVERALL HEIGHT-CTWT	8'-4.2"
D	WORKING HEIGHT-GANTRY	17'-10.4"
E	CTWT TAILSWING	14'-1.25"
F	TREADMEMBER LENGTH	20'-2"
G	OPERATOR'S CAB HEIGHT	10'-7.8"
H	HEIGHT OF BOOM FOOT PIN	5'-9.8"
J	UPPER WIDTH	10'-5.6"
K	WIDTH OVER CATWALKS	13'-3.3"
L	RETRACTED WIDTH	11'-11"
M	EXTENDED WIDTH	17'-0"
N	TRACK SHOE WIDTH	36"
P	MINIMUM GROUND CLEARANCE	15.2"

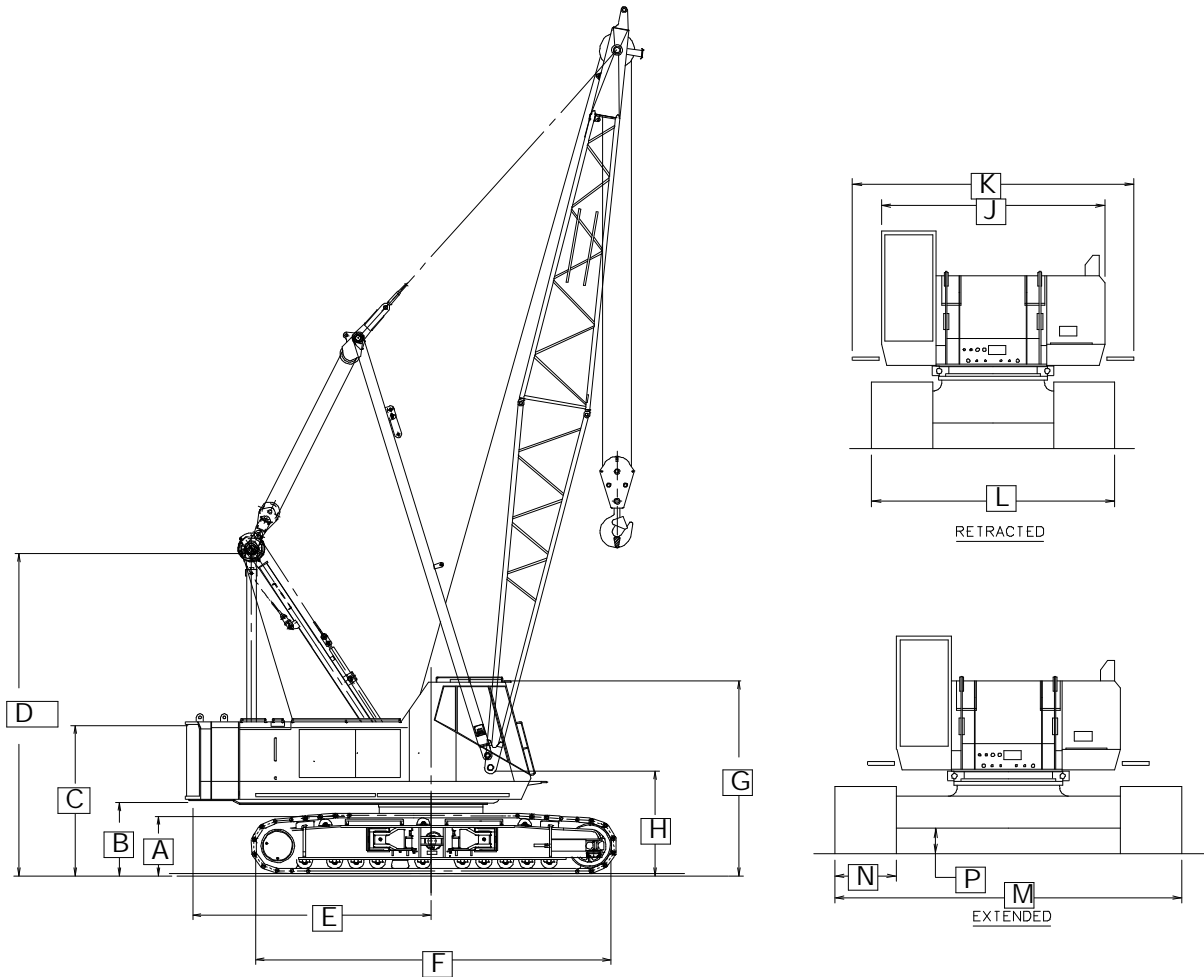

General Dimensions Drawing

LIFTOFF CAPABILITIES

Counterweight (Side Frames)	Maximum Boom	Maximum Boom + Jib
	Feet	Feet
NO (RETRACTED)	90	N/A
NO (EXTENDED)	120	N/A
A (RETRACTED)	140	N/A
A (EXTENDED)	170	N/A
AB (EXTENDED)	200	180 + 60 190 + 30

- NOTES:**
1. Booms must be erected or lowered over the end with no load - - hook block on ground.
 2. Crane on firm and level surface.
 3. Open throat booms 190' and 200' in length require mid-point suspension pendants.
 4. Boom and jib combination of 190' + 30' does require mid-point suspension pendants.
 5. Boom and jib combination of 180' + 60' does not require mid-point suspension pendants.

WORKING RANGE DIAGRAM

40' TO 200' OPEN THROAT BOOM

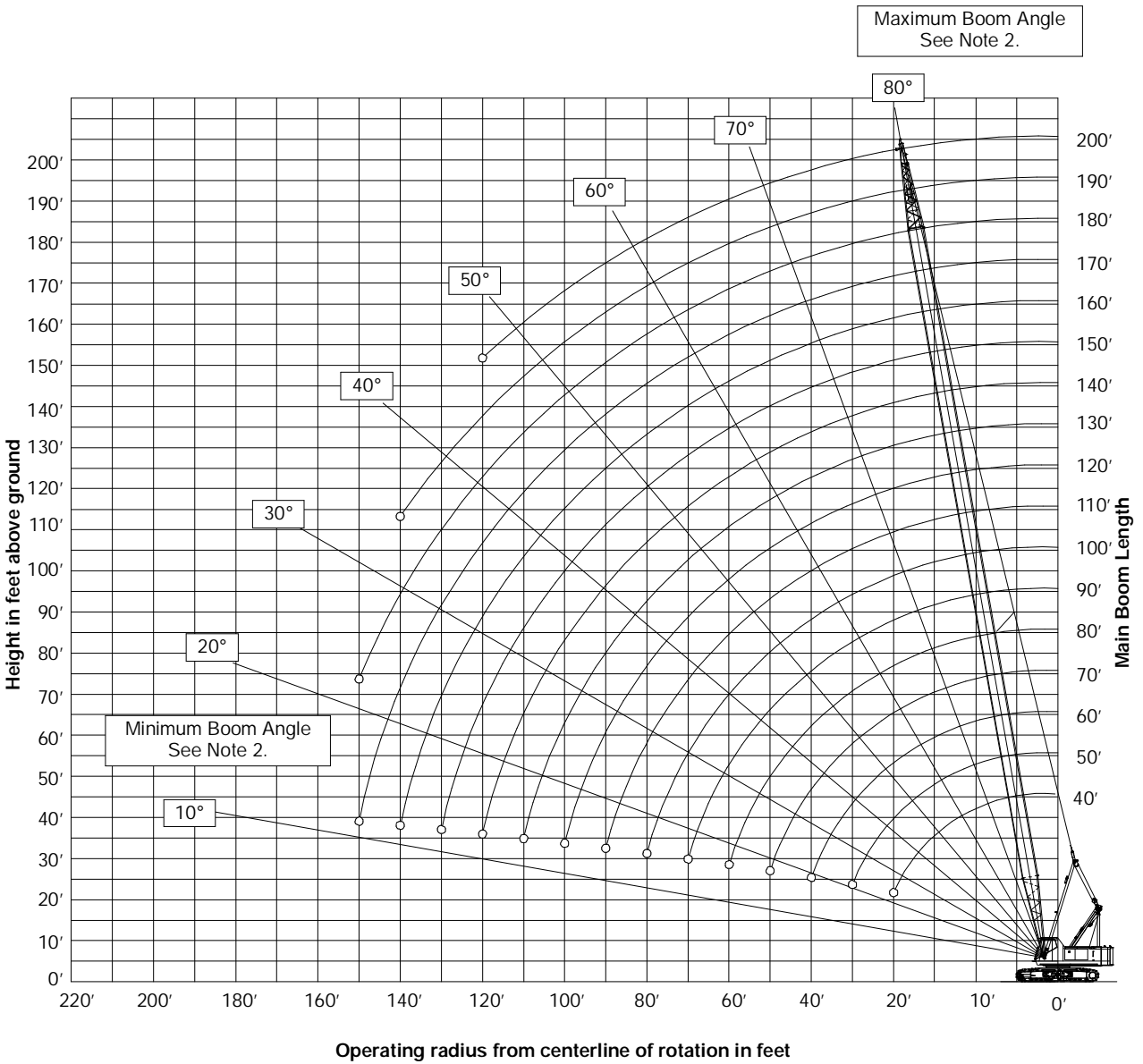

Notes:

1. Boom geometry shown is for unloaded condition and crane standing level on firm supporting surface. Boom deflection, subsequent radius and boom angle change must be accounted for when applying load to hook.
2. Maximum and minimum boom angles are equal to the values listed in the capacity chart for each boom length.

CAPACITY DEDUCTIONS FOR LIFTING OFF MAIN BOOM HOOK WITH JIB INSTALLED (OPEN THROAT BOOM ONLY)

When using main boom hook, while jib is attached, reduce boom capacities by the values in the following chart:

Jib Length (ft)	Capacity Deduction (lbs)
30	2,000
45	2,400
60	3,200

CAPACITY DEDUCTIONS FOR LIFTING OFF MAIN BOOM HOOK WITH 5 FOOT TIP EXTENSION INSTALLED

When using main boom hook, while 5 foot tip extension is attached, reduce boom capacities by the values in the following chart:

Tip Extension (ft)	Capacity Deduction (lbs)
5	1,100

MAXIMUM ALLOWABLE CAPACITIES FOR 5 FOOT TIP EXTENSION

LIFTING CAPACITY TO BE THE SMALLEST OF THE FOLLOWING VALUES:

1. 18,000 lb (Maximum).
2. The standard crane lift capacity minus 1,100 lb for the boom length, tip extension load radius, and counterweight configuration in use on the crane.

NOTES:

1. All notes are to be adhered to as listed on the standard lift crane capacity charts .
2. Reduce the main boom lift capacities by 1,100 lb when the tip extension is installed.
3. The maximum boom length on which the tip extension can be installed is 190'.
4. Do not lift or suspend a load from the boom tip extension and main boom at the same time.

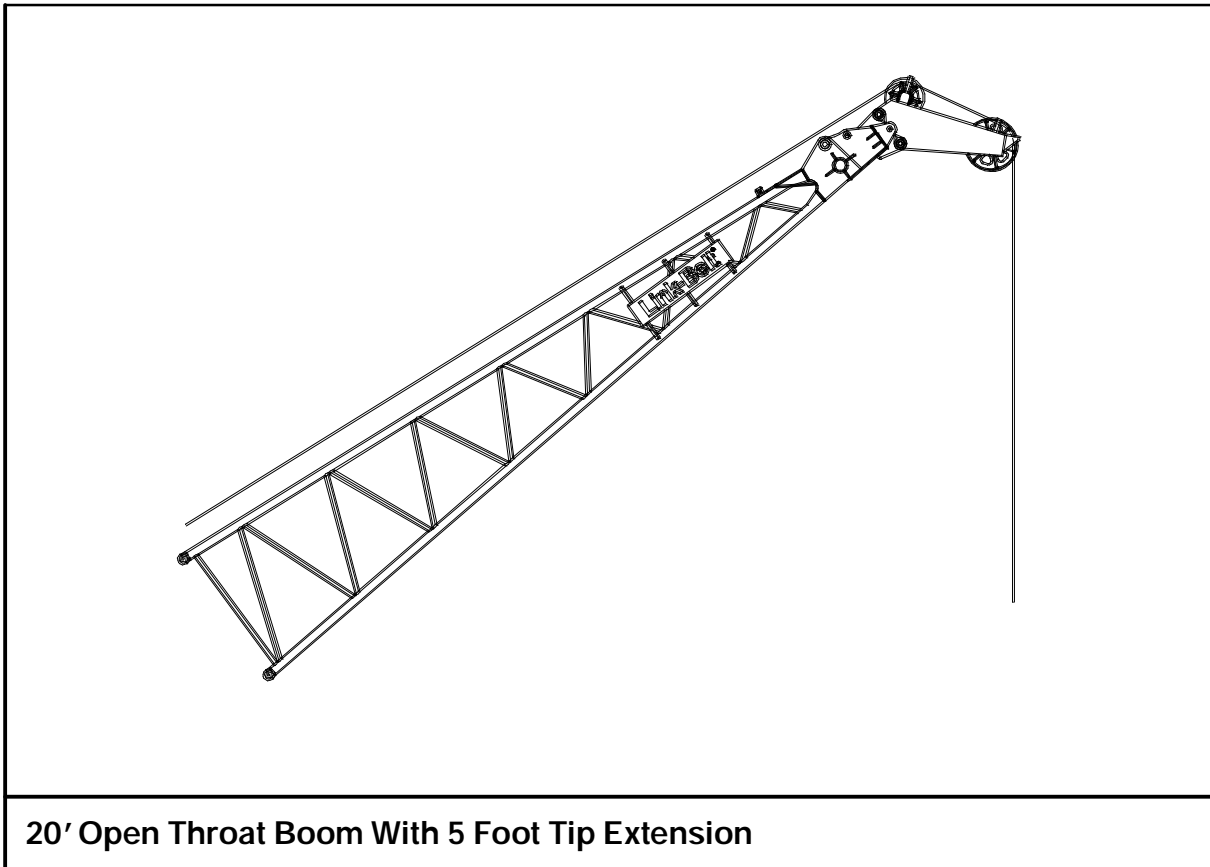

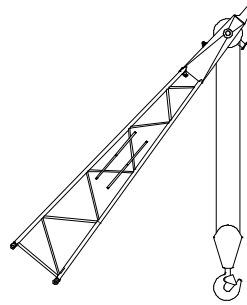
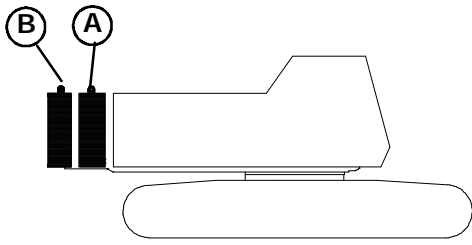

MAIN BOOM CAPACITIES – 40 FT OPEN THROAT TUBE BOOM

Load Radius (Ft.)	Boom Angle (deg)	Over End Blocked	360_Rotation					Load Radius (Ft.)
			Side Frames Extended			Side Frames Retracted		
			AB CTWT (lb)	A CTWT (lb)	0 CTWT (lb)	A CTWT (lb)	0 CTWT (lb)	
9	81.8	160,000	160,000	160,000	160,000	143,300	77,200	9
10	80.3	160,000	160,000	160,000	153,200	116,900	62,800	10
11	78.9	160,000	160,000	157,600	123,000	98,600	52,700	11
12	77.4	160,000	160,000	145,300	98,100	85,100	45,300	12
13	75.9	151,900	151,900	134,800	81,500	74,800	39,700	13
14	74.5	141,600	141,600	118,600	69,500	66,600	35,200	14
15	73.0	132,600	132,600	103,500	60,500	60,000	31,500	15
16	71.5	124,700	124,700	91,800	53,500	54,500	28,500	16
17	69.9	117,600	117,600	82,300	47,900	49,900	26,000	17
18	68.4	111,300	108,700	74,600	43,300	46,000	23,900	18
19	66.9	105,600	99,500	68,200	39,400	42,600	22,000	19
20	65.3	100,400	91,600	62,700	36,200	39,700	20,400	20
25	57.1	80,200	65,400	44,500	25,300	29,200	14,600	25
30	48.1	60,900	50,500	34,100	19,100	22,900	11,100	30
35	37.5	48,800	40,900	27,400	15,100	18,600	8,700	35
40	23.4	40,500	34,100	22,700	12,200	15,400	7,000	40

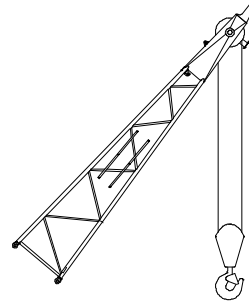
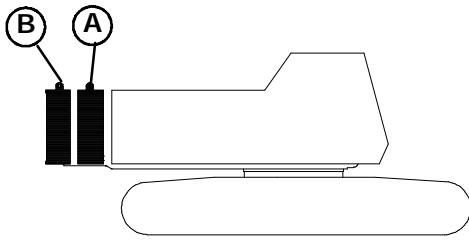

MAIN BOOM CAPACITIES – 50 FT OPEN THROAT TUBE BOOM

Load Radius (Ft.)	Boom Angle (deg)	Over End Blocked	360_Rotation					Load Radius (Ft.)
			Side Frames Extended			Side Frames Retracted		
			AB CTWT (lb)	AB CTWT (lb)	A CTWT (lb)	0 CTWT (lb)	A CTWT (lb)	
11	81.1	159,900	159,900	157,300	123,900	99,000	53,100	11
12	80.0	159,900	159,900	145,100	98,900	85,500	45,700	12
13	78.8	151,700	151,700	134,600	82,100	75,100	40,000	13
14	77.6	141,500	141,500	119,100	70,000	66,900	35,500	14
15	76.4	132,500	132,500	104,000	61,000	60,300	31,800	15
16	75.3	124,600	124,600	92,200	53,900	54,800	28,800	16
17	74.1	117,500	117,500	82,700	48,300	50,200	26,200	17
18	72.9	111,200	109,100	75,000	43,600	46,200	24,100	18
19	71.7	105,500	99,800	68,500	39,800	42,800	22,200	19
20	70.5	100,300	91,900	63,000	36,500	39,900	20,600	20
25	64.3	80,200	65,600	44,700	25,500	29,400	14,800	25
30	57.7	61,100	50,700	34,300	19,300	23,000	11,300	30
35	50.6	49,000	41,100	27,600	15,300	18,700	8,900	35
40	42.7	40,700	34,400	22,900	12,400	15,600	7,200	40
50	20.9	30,000	25,500	16,800	8,700	11,400	4,800	50

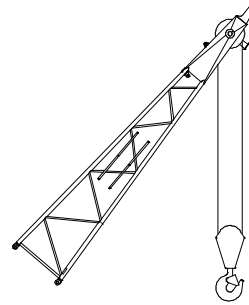
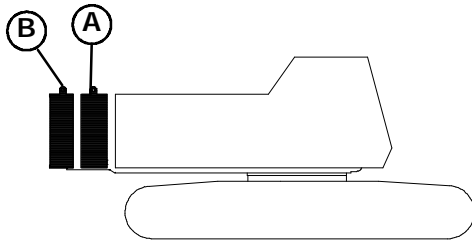

MAIN BOOM CAPACITIES – 60 FT OPEN THROAT TUBE BOOM

Load Radius (Ft.)	Boom Angle (deg)	Over End Blocked	360_Rotation					Load Radius (Ft.)
			Side Frames Extended			Side Frames Retracted		
			AB CTWT (lb)	AB CTWT (lb)	A CTWT (lb)	0 CTWT (lb)	A CTWT (lb)	
12	81.6	149,600	149,600	144,800	99,300	85,600	45,900	12
13	80.7	146,400	146,400	134,400	82,500	75,300	40,100	13
14	79.7	141,200	141,200	119,400	70,400	67,000	35,600	14
15	78.7	132,300	132,300	104,200	61,300	60,400	31,900	15
16	77.8	124,400	124,400	92,400	54,200	54,900	28,900	16
17	76.8	117,400	117,400	82,900	48,500	50,300	26,300	17
18	75.8	111,100	109,300	75,100	43,800	46,300	24,200	18
19	74.8	105,400	99,900	68,700	39,900	42,900	22,300	19
20	73.8	100,200	92,100	63,200	36,600	39,900	20,600	20
25	68.8	80,200	65,700	44,800	25,600	29,400	14,800	25
30	63.6	61,200	50,800	34,400	19,400	23,000	11,300	30
35	58.1	49,100	41,100	27,700	15,300	18,700	8,900	35
40	52.3	40,800	34,400	23,000	12,500	15,600	7,200	40
50	38.9	30,100	25,600	16,800	8,800	11,400	4,800	50
60	19.0	23,600	20,100	13,000	6,400	8,700	3,300	60

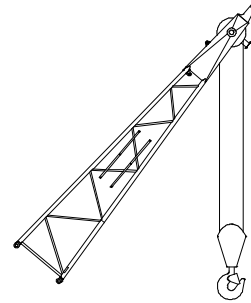
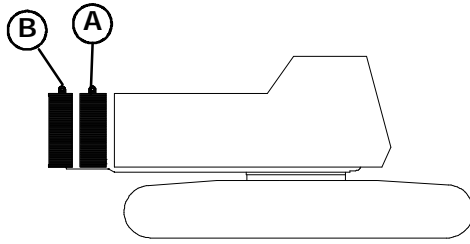

MAIN BOOM CAPACITIES - 70 FT OPEN THROAT TUBE BOOM

Load Radius (Ft.)	Boom Angle (deg)	Over End Blocked	360_Rotation					Load Radius (Ft.)
			Side Frames Extended			Side Frames Retracted		
			AB CTWT (lb)	AB CTWT (lb)	A CTWT (lb)	0 CTWT (lb)	A CTWT (lb)	
14	81.2	129,700	129,700	119,600	70,600	67,100	35,700	14
15	80.4	126,800	126,800	104,400	61,400	60,400	32,000	15
16	79.5	124,100	124,100	92,600	54,300	54,900	28,900	16
17	78.7	117,100	117,100	83,000	48,600	50,300	26,400	17
18	77.9	110,800	109,400	75,200	43,900	46,300	24,200	18
19	77.0	105,200	100,000	68,700	40,000	42,900	22,300	19
20	76.2	100,000	92,100	63,200	36,700	39,900	20,600	20
25	71.9	80,200	65,700	44,800	25,600	29,400	14,800	25
30	67.6	61,200	50,800	34,400	19,400	23,000	11,300	30
35	63.1	49,100	41,100	27,700	15,300	18,700	8,900	35
40	58.4	40,800	34,400	23,000	12,500	15,600	7,100	40
50	48.1	30,100	25,600	16,800	8,800	11,400	4,800	50
60	35.9	23,600	20,100	13,000	6,400	8,700	3,300	60
70	17.6	19,100	16,300	10,300	4,800	6,800	2,200	70

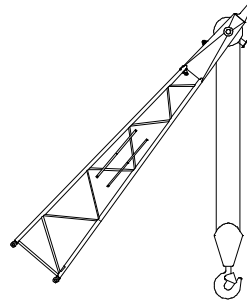
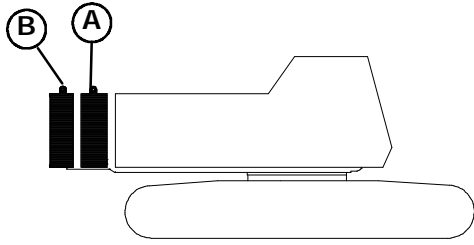

MAIN BOOM CAPACITIES – 80 FT OPEN THROAT TUBE BOOM

Load Radius (Ft.)	Boom Angle (deg)	Over End Blocked	360_Rotation				Load Radius (Ft.)	
			Side Frames Extended		Side Frames Retracted			
			AB CTWT (lb)	AB CTWT (lb)	A CTWT (lb)	0 CTWT (lb)		A CTWT (lb)
15	81.6	116,800	116,800	104,500	61,600	60,400	32,000	15
16	80.9	114,600	114,600	92,700	54,400	54,900	28,900	16
17	80.1	111,400	111,400	83,100	48,700	50,300	26,300	17
18	79.4	109,300	109,300	75,300	44,000	46,300	24,100	18
19	78.7	104,900	100,100	68,800	40,100	42,900	22,200	19
20	77.9	99,800	92,200	63,300	36,700	39,900	20,600	20
25	74.2	80,000	65,700	44,800	25,600	29,400	14,700	25
30	70.5	61,200	50,700	34,400	19,300	22,900	11,200	30
35	66.6	49,000	41,100	27,600	15,300	18,600	8,800	35
40	62.7	40,700	34,300	22,900	12,400	15,500	7,100	40
50	54.3	30,100	25,500	16,800	8,700	11,300	4,700	50
60	44.8	23,500	20,000	12,900	6,400	8,600	3,200	60
70	33.5	19,100	16,300	10,300	4,800	6,700	2,100	70
80	16.5	15,900	13,500	8,300	3,600	5,300	-----	80

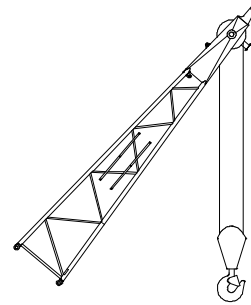
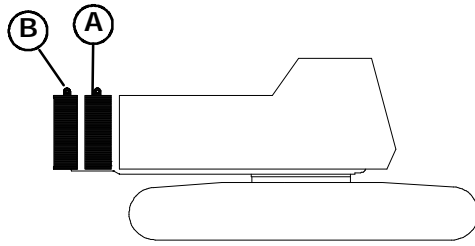

MAIN BOOM CAPACITIES - 90 FT OPEN THROAT TUBE BOOM

Load Radius (Ft.)	Boom Angle (deg)	Over End Blocked	360_Rotation					Load Radius (Ft.)
			Side Frames Extended			Side Frames Retracted		
			AB CTWT (lb)	AB CTWT (lb)	A CTWT (lb)	0 CTWT (lb)	A CTWT (lb)	
16	81.9	104,700	104,700	92,700	54,500	54,900	28,900	16
17	81.2	102,800	102,800	83,200	48,700	50,200	26,300	17
18	80.6	101,200	101,200	75,300	44,000	46,200	24,100	18
19	79.9	99,600	99,600	68,800	40,100	42,800	22,200	19
20	79.3	97,700	92,200	63,300	36,700	39,800	20,500	20
25	76.0	79,800	65,700	44,800	25,600	29,300	14,700	25
30	72.7	61,200	50,700	34,300	19,300	22,800	11,100	30
35	69.4	49,000	41,000	27,500	15,200	18,500	8,700	35
40	65.9	40,700	34,200	22,800	12,300	15,400	6,900	40
50	58.7	30,000	25,400	16,700	8,600	11,200	4,600	50
60	50.9	23,500	19,900	12,800	6,300	8,500	3,100	60
70	42.2	19,000	16,200	10,200	4,700	6,600	2,000	70
80	31.5	15,800	13,400	8,300	3,500	5,200	-----	80
90	15.5	13,400	11,300	6,800	2,600	4,100	-----	90

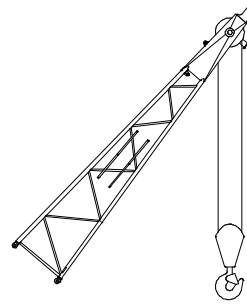
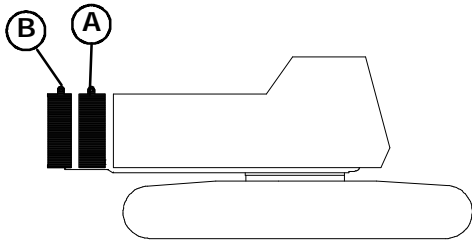

MAIN BOOM CAPACITIES - 100 FT OPEN THROAT TUBE BOOM

Load Radius (Ft.)	Boom Angle (deg)	Over End Blocked	360_Rotation				Load Radius (Ft.)
			Side Frames Extended		Side Frames Retracted		
			AB CTWT (lb)	A CTWT (lb)	0 CTWT (lb)	0 CTWT (lb)	
18	81.5	93,400	93,400	75,300	44,000	46,200	18
19	81.0	92,000	92,000	68,800	40,000	42,700	19
20	80.4	89,400	89,400	63,200	36,700	39,700	20
25	77.5	79,600	65,600	44,700	25,500	29,200	25
30	74.5	61,100	50,600	34,200	19,200	22,700	30
35	71.5	48,900	40,900	27,400	15,100	18,400	35
40	68.5	40,600	34,100	22,700	12,200	15,300	40
50	62.1	29,900	25,300	16,600	8,500	11,100	50
60	55.4	23,400	19,800	12,700	6,200	8,400	60
70	48.2	18,900	16,100	10,100	4,600	6,500	70
80	39.9	15,700	13,300	8,100	3,400	5,100	80
90	29.9	13,300	11,200	6,700	2,500	4,000	90
100	14.7	11,400	9,500	5,500	-----	3,100	100

PROHIBITED

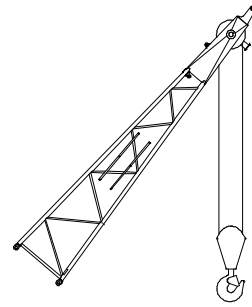
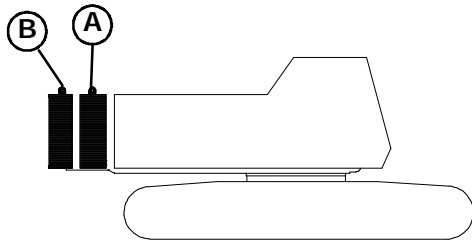

MAIN BOOM CAPACITIES - 110 FT OPEN THROAT TUBE BOOM

Load Radius (Ft.)	Boom Angle (deg)	Over End Blocked	360_Rotation					Load Radius (Ft.)
			Side Frames Extended			Side Frames Retracted		
			AB CTWT (lb)	AB CTWT (lb)	A CTWT (lb)	0 CTWT (lb)	A CTWT (lb)	
25	78.6	77,100	65,500	44,600	25,400	29,000	PROHIBITED	25
30	75.9	61,000	50,500	34,100	19,100	22,600		30
35	73.2	48,800	40,800	27,300	15,000	18,200		35
40	70.5	40,500	34,000	22,600	12,100	15,100		40
50	64.9	29,800	25,200	16,400	8,400	10,900		50
60	59.0	23,200	19,700	12,600	6,000	8,200		60
70	52.7	18,800	15,900	9,900	4,400	6,400		70
80	45.8	15,600	13,200	8,000	3,300	5,000		80
90	38.0	13,200	11,100	6,500	2,400	3,900		90
100	28.4	11,300	9,400	5,400	-----	3,000		100
110	14.0	9,700	8,100	4,400	-----	2,300		110

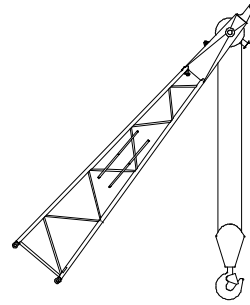
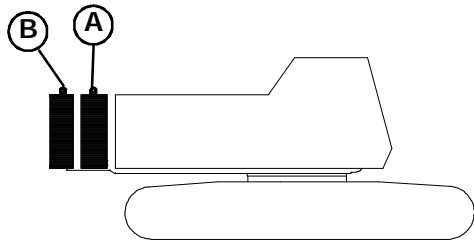

MAIN BOOM CAPACITIES - 120 FT OPEN THROAT TUBE BOOM

Load Radius (Ft.)	Boom Angle (deg)	Over End Blocked	360_Rotation				Load Radius (Ft.)
			Side Frames Extended		Side Frames Retracted		
			AB CTWT (lb)	A CTWT (lb)	0 CTWT (lb)	0 CTWT (lb)	
25	79.6	71,600	65,500	44,600	25,400	28,900	25
30	77.1	61,000	50,400	34,000	19,000	22,500	30
35	74.7	48,700	40,700	27,200	14,900	18,100	35
40	72.2	40,400	33,900	22,500	12,000	15,000	40
50	67.1	29,700	25,100	16,300	8,200	10,800	50
60	61.8	23,100	19,500	12,400	5,900	8,100	60
70	56.2	18,700	15,800	9,800	4,300	6,200	70
80	50.3	15,500	13,000	7,900	3,100	4,800	80
90	43.7	13,000	10,900	6,400	2,200	3,700	90
100	36.3	11,100	9,300	5,200	-----	2,900	100
110	27.2	9,600	8,000	4,300	-----	2,200	110
120	13.4	8,300	6,800	3,500	-----	-----	120

PROHIBITED

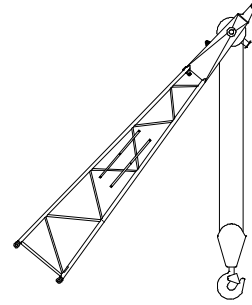
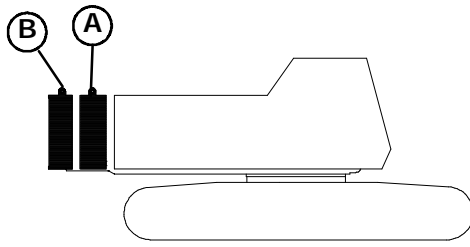

MAIN BOOM CAPACITIES - 130 FT OPEN THROAT TUBE BOOM

Load Radius (Ft.)	Boom Angle (deg)	Over End Blocked	360_Rotation				Side Frames Retracted		Load Radius (Ft.)
			Side Frames Extended				A	0	
			AB CTWT (lb)	AB CTWT (lb)	A CTWT (lb)	0 CTWT (lb)	CTWT (lb)	CTWT (lb)	
25	80.4	65,100	65,100	44,500	PROHIBITED	28,800	PROHIBITED	25	
30	78.1	60,900	50,300	33,900		22,300		30	
35	75.9	48,600	40,600	27,100		18,000		35	
40	73.6	40,200	33,800	22,300		14,800		40	
50	68.9	29,500	24,900	16,200		10,600		50	
60	64.1	23,000	19,400	12,300		7,900		60	
70	59.1	18,500	15,600	9,600		6,000		70	
80	53.8	15,300	12,900	7,700		4,700		80	
90	48.2	12,900	10,800	6,300		3,600		90	
100	41.9	11,000	9,200	5,100		2,700		100	
110	34.8	9,500	7,800	4,200		2,000		110	
120	26.1	8,200	6,700	3,400		-----		120	
130	12.9	7,100	5,800	2,700		-----		130	

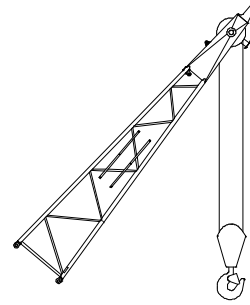
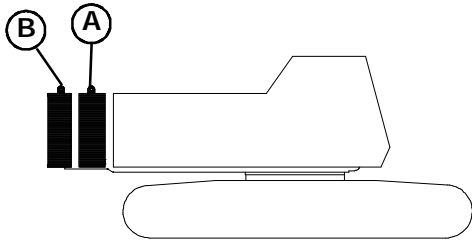

MAIN BOOM CAPACITIES - 140 FT OPEN THROAT TUBE BOOM

Load Radius (Ft.)	Boom Angle (deg)	Over End Blocked	360_Rotation				Load Radius (Ft.)
			Side Frames Extended		Side Frames Retracted		
			AB CTWT (lb)	A CTWT (lb)	0 CTWT (lb)	0 CTWT (lb)	
25	81.1	60,000	60,000	44,400	PROHIBITED	28,700	25
30	79.0	56,700	50,200	33,800		22,200	30
35	76.9	48,500	40,400	27,000		17,800	35
40	74.8	40,100	33,600	22,200		14,700	40
50	70.5	29,400	24,800	16,000		10,500	50
60	66.1	22,800	19,200	12,100		7,800	60
70	61.5	18,400	15,500	9,500		5,900	70
80	56.8	15,200	12,700	7,600		4,500	80
90	51.7	12,700	10,600	6,100		3,400	90
100	46.3	10,800	9,000	4,900		2,600	100
110	40.3	9,300	7,700	4,000		-----	110
120	33.5	8,000	6,600	3,200		-----	120
130	25.2	7,000	5,600	2,600		-----	130
140	12.4	6,100	4,800	2,000		-----	140

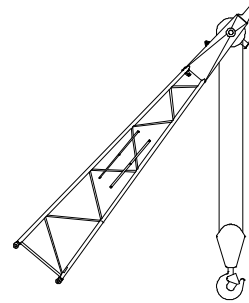
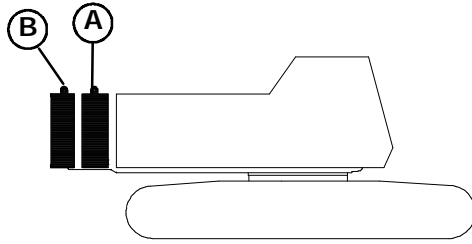

MAIN BOOM CAPACITIES - 150 FT OPEN THROAT TUBE BOOM

Load Radius (Ft.)	Boom Angle (deg)	Over End Blocked	360_Rotation					Load Radius (Ft.)
			Side Frames Extended			Side Frames Retracted		
			AB CTWT (lb)	AB CTWT (lb)	A CTWT (lb)	0 CTWT (lb)	A CTWT (lb)	
25	81.7	55,100	55,100	44,300	PROHIBITED	25		
30	79.7	52,200	50,000	33,700		30		
35	77.8	48,400	40,300	26,800		35		
40	75.8	40,000	33,500	22,100		40		
50	71.9	29,200	24,600	15,900		50		
60	67.8	22,700	19,100	12,000		60		
70	63.6	18,200	15,300	9,300		70		
80	59.2	15,000	12,600	7,400		80		
90	54.7	12,600	10,500	5,900		90		
100	49.9	10,700	8,800	4,800		100		
110	44.6	9,100	7,500	3,800		110		
120	38.9	7,900	6,400	3,100		120		
130	32.4	6,800	5,500	2,400		130		
140	24.3	5,900	4,700	-----		140		
150	12.0	5,100	4,000	-----		150		

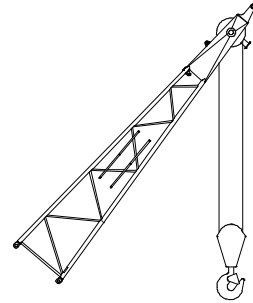
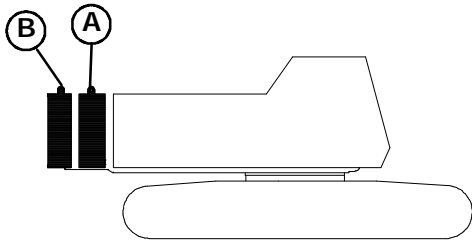

MAIN BOOM CAPACITIES - 160 FT OPEN THROAT TUBE BOOM

Load Radius (Ft.)	Boom Angle (deg)	Over End Blocked	360_Rotation				Load Radius (Ft.)
			Side Frames Extended		Side Frames Retracted		
			AB CTWT (lb)	AB CTWT (lb)	A CTWT (lb)	0 CTWT (lb)	
30	80.4	47,900	47,900	33,500	PROHIBITED	30	
35	78.6	44,000	40,200	26,700		35	
40	76.7	39,900	33,300	21,900		40	
50	73.0	29,100	24,500	15,700		50	
60	69.2	22,500	18,900	11,800		60	
70	65.4	18,000	15,100	9,200		70	
80	61.3	14,800	12,400	7,200		80	
90	57.2	12,400	10,300	5,800		90	
100	52.8	10,500	8,700	4,600		100	
110	48.2	9,000	7,300	3,700		110	
120	43.2	7,700	6,200	2,900		120	
130	37.6	6,700	5,300	2,200		130	
140	31.3	5,800	4,500	-----		140	
150	23.5	5,000	3,800	-----		150	
160	11.6	4,300	3,200	-----		160	

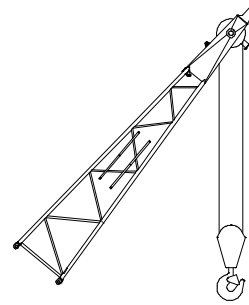
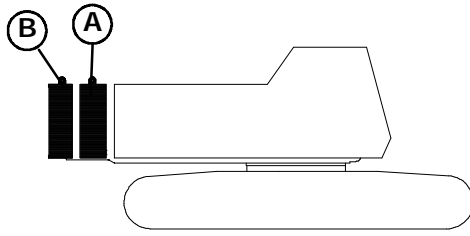

MAIN BOOM CAPACITIES - 170 FT OPEN THROAT TUBE BOOM

Load Radius (Ft.)	Boom Angle (deg)	Over End Blocked	360_Rotation				Load Radius (Ft.)
			Side Frames Extended		Side Frames Retracted		
			AB CTWT (lb)	A CTWT (lb)	0 CTWT (lb)	0 CTWT (lb)	
30	81.0	42,400	42,400	33,400	PROHIBITED	30	
35	79.2	40,300	40,000	26,600		35	
40	77.5	37,000	33,200	21,800		40	
50	74.0	28,900	24,300	15,500		50	
60	70.5	22,300	18,800	11,700		60	
70	66.9	17,900	15,000	9,000		70	
80	63.2	14,700	12,200	7,100		80	
90	59.3	12,200	10,100	5,600		90	
100	55.3	10,300	8,500	4,400		100	
110	51.1	8,800	7,200	3,500		110	
120	46.6	7,500	6,100	2,700		120	
130	41.8	6,500	5,100	2,100		130	
140	36.5	5,600	4,400	-----		140	
150	30.3	4,800	3,700	-----		150	
160	22.8	4,100	3,100	-----		160	
170	11.3	3,500	2,500	-----		170	

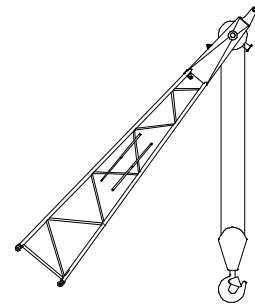
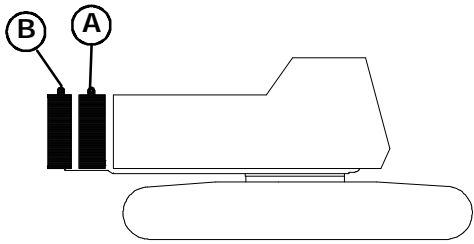

MAIN BOOM CAPACITIES - 180 FT OPEN THROAT TUBE BOOM

Load Radius (Ft.)	Boom Angle (deg)	Over End Blocked	360_Rotation				Load Radius (Ft.)
			Side Frames Extended		Side Frames Retracted		
			AB CTWT (lb)	AB CTWT (lb)	A CTWT (lb)	0 CTWT (lb)	
30	81.5	37,500	37,500	PROHIBITED	PROHIBITED	PROHIBITED	PROHIBITED
35	79.9	36,800	36,800				
40	78.2	33,900	33,000				
50	75.0	28,100	24,100				
60	71.6	21,900	18,600				
70	68.2	17,700	14,800				
80	64.8	14,500	12,000				
90	61.2	12,100	10,000				
100	57.5	10,200	8,300				
110	53.6	8,600	7,000				
120	49.6	7,400	5,900				
130	45.3	6,100	5,000				
140	40.6	5,000	4,200				
150	35.4	4,100	3,500				
160	29.5	3,300	2,900				
170	22.1	2,500	2,400				

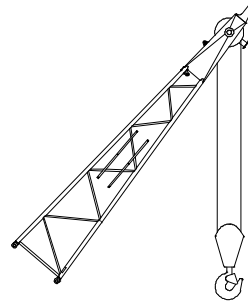
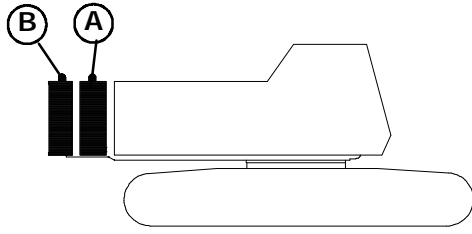

MAIN BOOM CAPACITIES - 190 FT OPEN THROAT TUBE BOOM

Load Radius (Ft.)	Boom Angle (deg)	Over End Blocked	360_Rotation				Load Radius (Ft.)
			Side Frames Extended		Side Frames Retracted		
			AB CTWT (lb)	A CTWT (lb)	0 CTWT (lb)	A CTWT (lb)	
30	81.9	32,900	32,900	PROHIBITED		30	
35	80.4	32,500	32,500			35	
40	78.9	30,700	30,700			40	
50	75.8	25,700	24,000			50	
60	72.6	19,600	18,400			60	
70	69.4	16,200	14,600			70	
80	66.2	13,300	11,900			80	
90	62.8	11,000	9,800			90	
100	59.4	9,100	8,100			100	
110	55.8	7,500	6,800			110	
120	52.1	6,100	5,700			120	
130	48.2	5,000	4,800			130	
140	44.0	4,000	4,000			140	
150	39.4	3,100	3,100			150	
160	34.4	2,100	2,100	160			

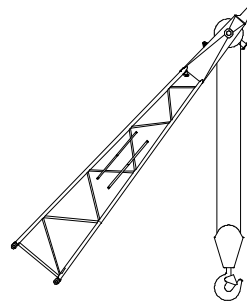
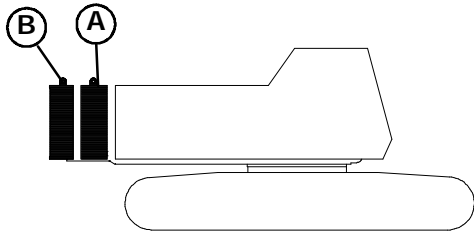

MAIN BOOM CAPACITIES – 200 FT OPEN THROAT TUBE BOOM

Load Radius (Ft.)	Boom Angle (deg)	Over End Blocked	360_Rotation				Load Radius (Ft.)	
			Side Frames Extended		Side Frames Retracted			
			AB CTWT (lb)	AB CTWT (lb)	A CTWT (lb)	0 CTWT (lb)		A CTWT (lb)
35	80.9	28,600	28,600	PROHIBITED				35
40	79.4	27,200	27,200					40
50	76.5	21,500	21,500					50
60	73.5	17,500	17,500					60
70	70.5	14,200	14,200					70
80	67.4	11,700	11,700					80
90	64.3	9,500	9,500					90
100	61.1	7,700	7,700					100
110	57.8	6,200	6,200					110
120	54.3	5,000	5,000					120
130	50.7	3,900	3,900					130
140	46.9	2,800	2,800	140				

LIVE MAST LIFTING CAPACITIES (WITHOUT COUNTERWEIGHT INSTALLED)

Live Mast		Side Frames Extended (lb)	Side Frames Retracted (lb)
Radius (ft)	Angle (deg)		
10	73.7	60,000	60,000
11	71.2	60,000	51,600
12	68.7	60,000	44,600
13	66.1	60,000	39,200
14	63.5	60,000	34,900
15	60.8	59,400	31,500
16	58.0	52,700	28,600
17	55.1	47,400	26,200
18	52.2	43,000	24,200
19	49.1	39,300	22,500
20	45.8	36,200	20,900
21	42.4	33,500	19,600
22	38.8	31,200	18,400
23	34.8	29,200	17,300
24	30.3	27,400	16,400

- NOTES:**
1. Refer to the Operator's Manual.
 2. Live mast backstops must be in position and operative.
 3. Use rear hoist drum only. Reeve hoist line to drum over live mast cross member.
 4. Reeve hoist rope with three (3) parts of 7/8" diameter wire rope.
 5. The crane shall be leveled on a firm supporting surface.
 6. Capacities are based on 75% stability.
 7. See Crane Assembly Component Weights chart for weight of components for crane assembly.
 8. Rated capacities for 360° rotation.
 9. Gantry can be either in the raised or lowered position when lifting loads with the live mast. When the gantry is in the lowered position the backstay links must be pinned.
 10. Do not lower live mast below 3° angle with gantry in lowered position.

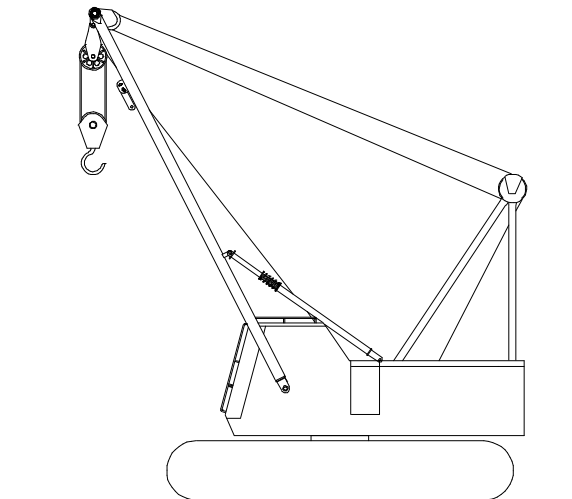

20' BASE SECTION CYLINDER LIFTING CAPACITIES (WITHOUT COUNTERWEIGHT INSTALLED)

Base Section Cylinders		Side Frames Extended (lb)	Side Frames Retracted (lb)
Radius (ft)	Angle (deg)		
15	55.0	26,500	26,500
16	50.9	26,500	26,500
17	46.4	26,500	26,100
18	41.6	26,500	23,900
19	36.0	26,500	22,000
20	29.5	26,500	20,300
21	20.6	26,500	18,700

- NOTES:
1. Rated capacities for 360_ rotation.
 2. Boom base section supported by make up pendants.
 3. Lifting any load with one cylinder is prohibited. Rated capacities are for lifting loads with both cylinders.
 4. Gantry can be either in the raised or lowered position when lifting loads with the cylinders in the base section. When the gantry is in the lowered position the backstay links must be pinned.
 5. Do not raise boom higher than 55_ angle.
 6. Do not lower live mast below 3_ angle with gantry in lowered position.

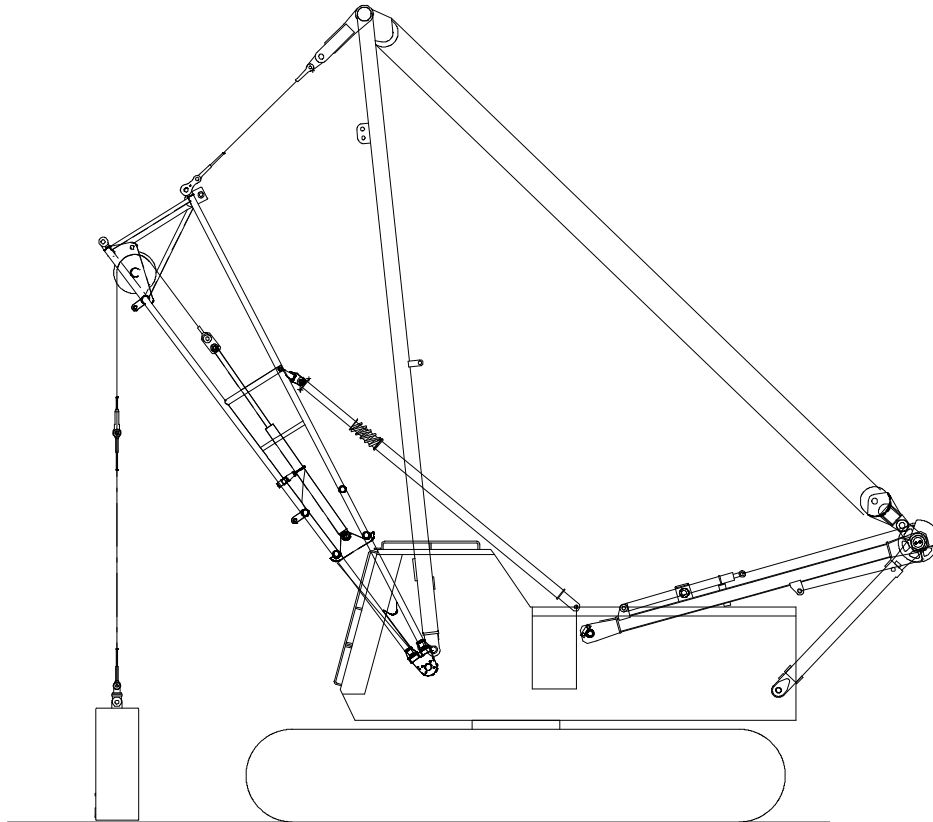

CRANE ASSEMBLY COMPONENT WEIGHTS

Component	Weight	
	lb	kg
1. 20 Ft Top Section With Sheave Machinery	2,695	1,123
2. 20 Ft Top Section With Sheave Machinery and 5Ft Tip Extension	3,606	1,635
3. 20 Ft Base Section With Lifting Cylinders	2,435	1,105
4. 20 Ft Base Section Without Lifting Cylinders	1,520	689
5. Boom Extensions		
D 10' Boom Extensions With Pendants	638	289
D 20' Boom Extensions With Pendants	1,034	469
D 30' Boom Extensions With Pendants	1,430	649
6. Upper Counterweights		
D Counterweight "A"	25,250	11,453
D Counterweight "B"	25,250	11,453
7. Side Frames (Each)	19,700	8,936

DUTY CYCLE NOTES FOR TUBULAR BOOM

1. The capacities included in this chart are the maximum allowable, and are based on machine standing level on firm supporting surface under ideal job conditions.
2. Capacities are based on 75% of minimum tipping loads for dragline; 67.5% for clamshell.
3. Capacities are maximum recommended by PCSA Standard #4. User must make allowances for soft or uneven supporting surfaces, rapid cycle operations, bucket suction or other unfavorable conditions which may require smaller buckets for most efficient operation.
4. Weight of bucket, plus load must not exceed these capacities.
5. Dragline operation is not recommended with boom angles less than 35°.
6. Boom length for dragline/clamshell attachment operation should not exceed 70'.
7. Retractable high gantry must be fixed in raised position for all capacities on this chart.
8. These capacities apply to the machine as originally manufactured and normally equipped by Link-Belt Construction Equipment Company.

DUTY CYCLE CAPACITIES – TUBULAR BOOM

Boom Length (ft)	Load Radius (ft)	Boom Angle (deg)	Side Frames Extended – “A” Counterweight Only (All capacities listed are in pounds)	
			Dragline	Clamshell/Magnet
40	15	73.0	----	15,800
40	20	65.3	----	15,800
40	25	57.1	15,800	15,800
40	30	48.1	15,800	15,800
40	35	37.5	15,800	15,800
40	40	23.4	----	15,800
50	20	70.5	----	15,800
50	25	64.3	----	15,800
50	30	57.7	15,800	15,800
50	35	50.6	15,800	15,800
50	40	42.7	15,800	15,800
50	50	20.9	----	15,800
60	25	68.8	----	15,800
60	30	63.6	----	15,800
60	35	58.1	15,800	15,800
60	40	52.3	15,800	15,800
60	50	38.9	15,800	15,800
60	60	19.0	----	11,700
70	25	71.9	----	15,800
70	30	67.6	----	15,800
70	35	63.1	----	15,800
70	40	58.4	15,800	15,800
70	50	48.1	15,800	15,800
70	60	35.9	13,000	11,700
70	70	17.6	----	9,300

TUBULAR JIB NOTES FOR OPEN THROAT BOOM

1. Capacities are for a LS-138H II crawler crane with AB (50,500 lb) counterweight.
2. Separate capacity charts are listed for 360_ and for over-end blocked crawler working areas. Verify operating conditions as described on the Working Area Chart found in the general information section of this Crane Rating Manual. Apply the appropriate lift capacity chart based on the working area and the specific operating conditions.
3. Over-end blocked capacities can be lifted over either end with the crane standing level on a firm supporting surface. Adequate blocking must be placed under the treadmember sprockets/idlers to prevent rocking.
4. Capacities are for side frames in the extended position only and are based on the crane standing level on a firm supporting surface.
5. Capacities are limited to a LBCE 44" x 54" tubular boom with an open throat and a LBCE 12 ton, 24" x 32" cross section jib with a 11'6" high jib mast properly assembled.
6. Two parts of 7/8" Diameter Type "DB" or Type "RB" wire rope are required for maximum lift.
7. Capacities are for 30', 45', and 60' jib lengths only.
8. A jib cannot be used on open throat boom lengths longer than 190'. Maximum boom plus jib combination is 180' + 60' or 190' + 30'. The only jib length available on 190' open throat boom is 30'. Midpoint pendants must be used with 190' + 30' combination.
9. The least stable condition is over the side.
10. All capacities are listed in pounds and are not more than 75% of the tipping loads. Those capacities followed by an asterisk (*) are governed by factors other than those that would cause a tipping condition.
11. A deduction must be made from the jib capacities for the weight of the following: Main boom hook block or hook ball, jib hook block or hook ball, slings, grapple, load weighing devices, etc.

TUBULAR JIB NOTES FOR OPEN THROAT BOOM

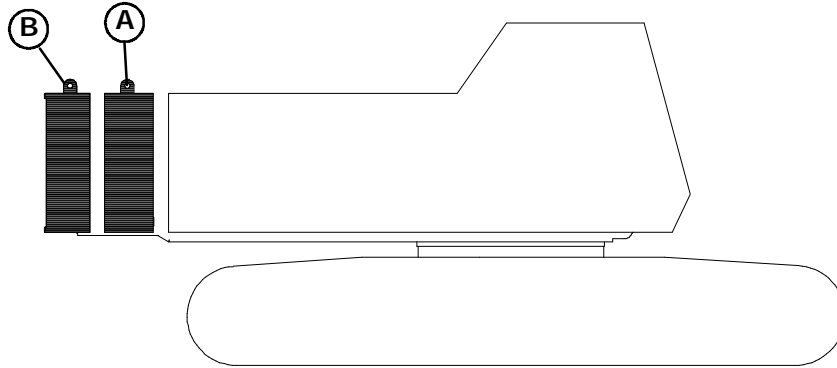

Full Counterweight Combination

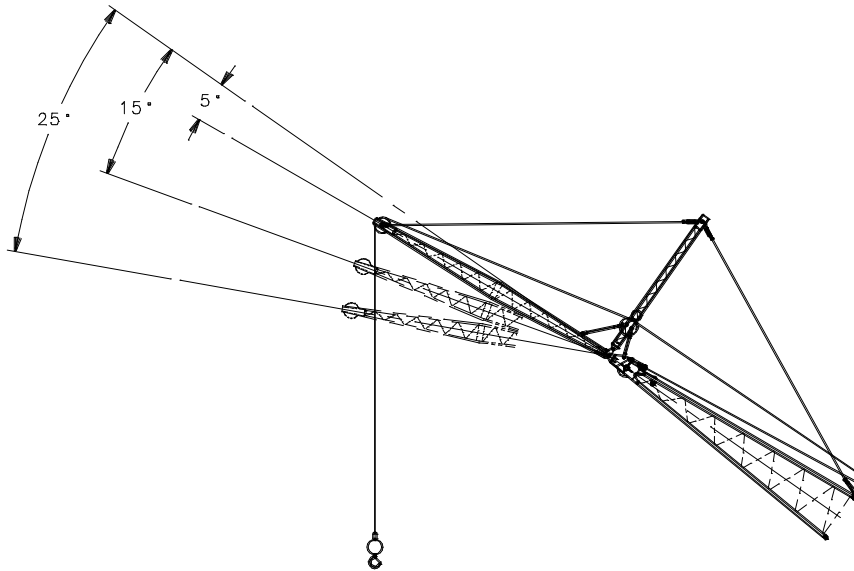

Tubular Jib Offset Angle Diagram

WORKING RANGE DIAGRAM

40' TO 180' MAIN BOOM WITH 30' TO 60' JIB

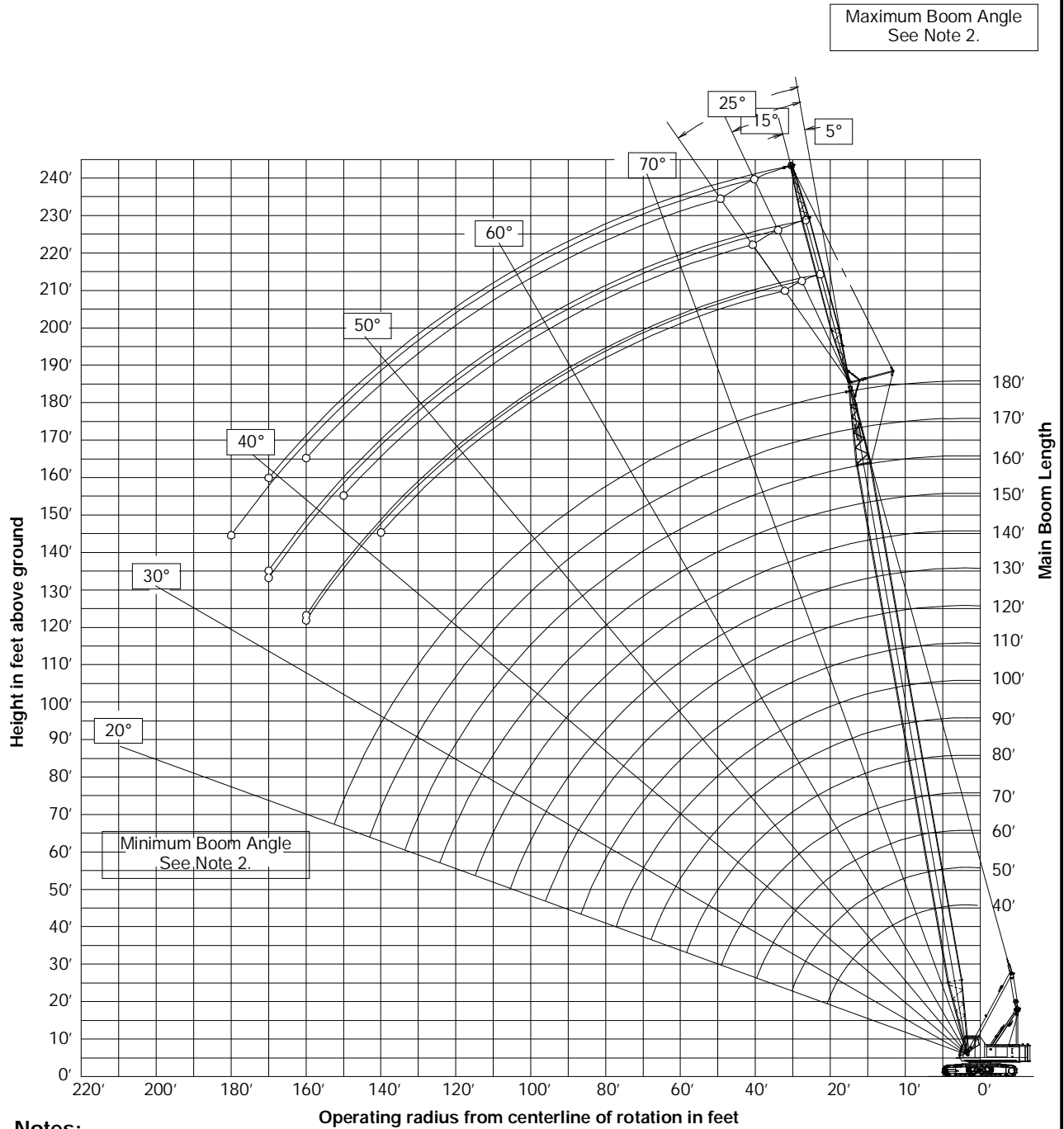

Notes:

1. Boom geometry shown is for unloaded condition and crane standing level on firm supporting surface. Boom deflection, subsequent radius and boom angle change must be accounted for when applying load to hook.
2. Maximum and minimum boom angles are equal to the values listed in the capacity chart for each boom length.

Working Range Diagram

WORKING RANGE DIAGRAM

190' MAIN BOOM WITH 30' JIB

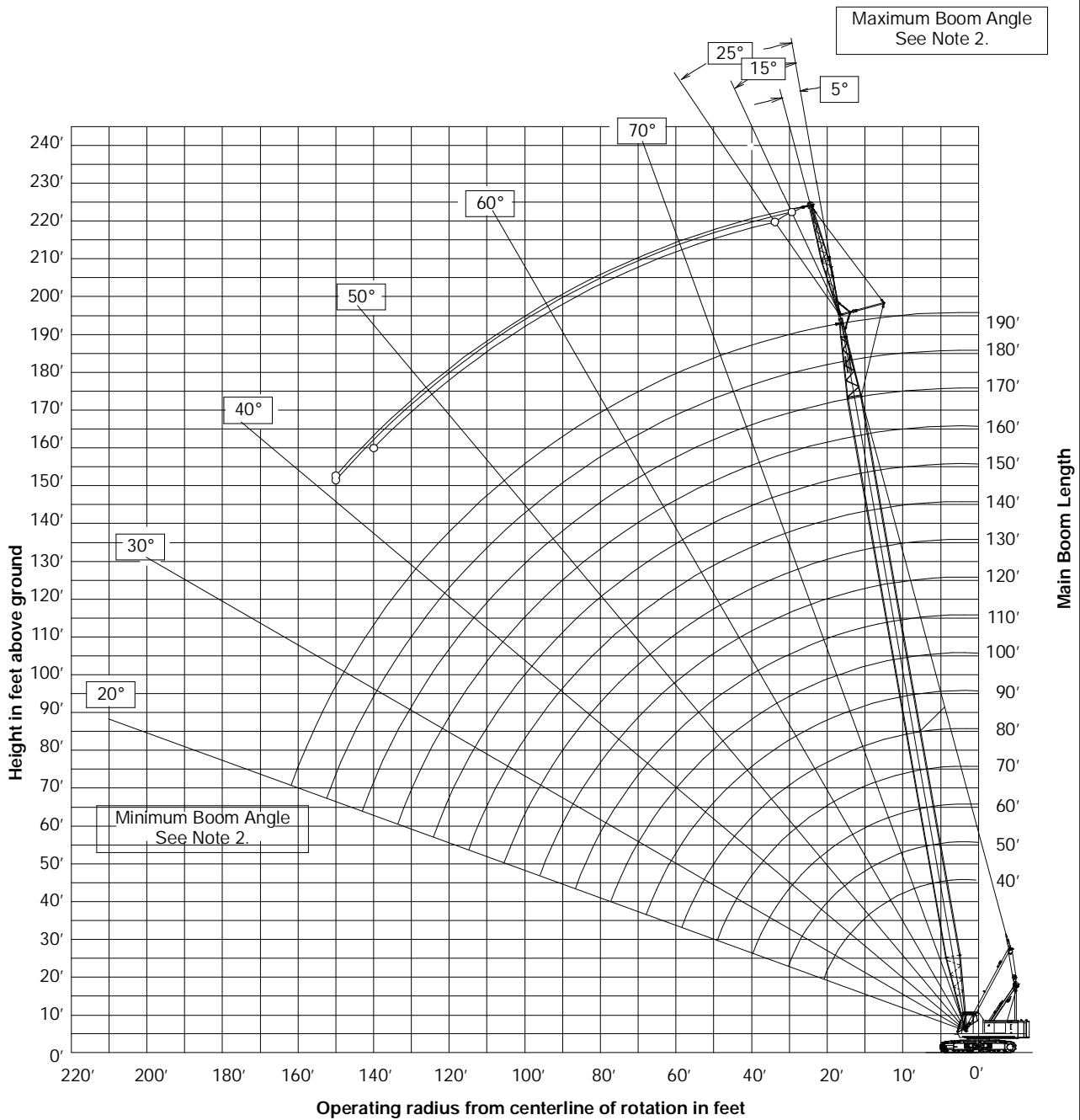

Notes:

1. Boom geometry shown is for unloaded condition and crane standing level on firm supporting surface. Boom deflection, subsequent radius and boom angle change must be accounted for when applying load to hook.
2. Maximum and minimum boom angles are equal to the values listed in the capacity chart for each boom length.

Working Range Diagram